

## SPECIFICATION SHEET: 500MM AXIAL FAN

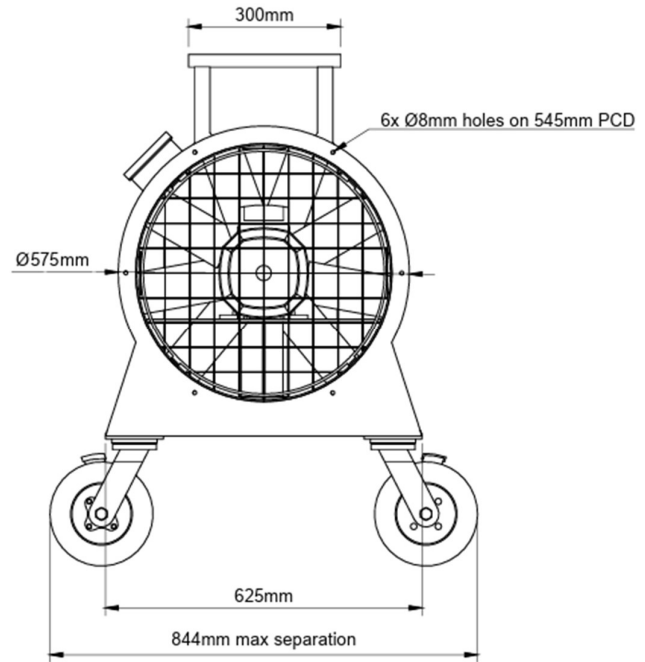
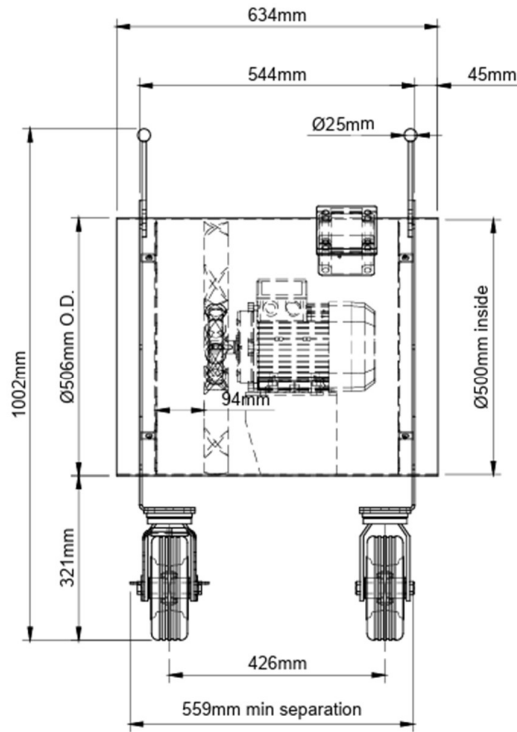

### Fan Information

<b>Max Air Flow:</b>	13,525m <sup>3</sup> /hr
<b>Noise Level:</b>	79dBA @ 1m
<b>Motor:</b>	2.2kW
<b>Power:</b>	240V, 15A
<b>Power Outlet:</b>	2 Phase
<b>Duct Diameter:</b>	305mm
<b>Dimensions (mm):</b>	510L x 575W x 700H
<b>Weight:</b>	69kg
<b>Lifting Method:</b>	Handles
<b>Silencer:</b>	Optional

### Fan Curve

