

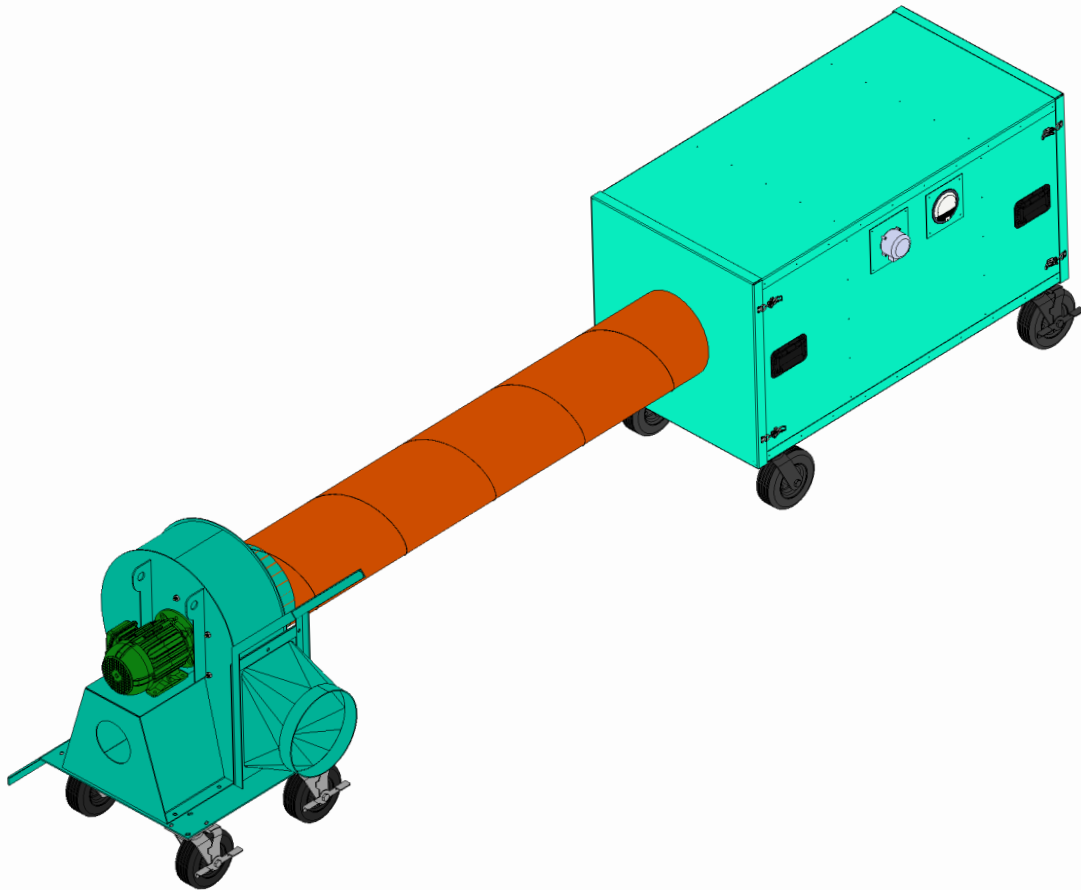

SPECIFICATION SHEET: 5800 AIR SCRUBBER KIT



5800 Air Scrubber Kit Includes:

5800 Air Scrubber

300mm Centrifugal Fan

SPECIFICATION SHEET: 5800M³/HR AIR SCRUBBER

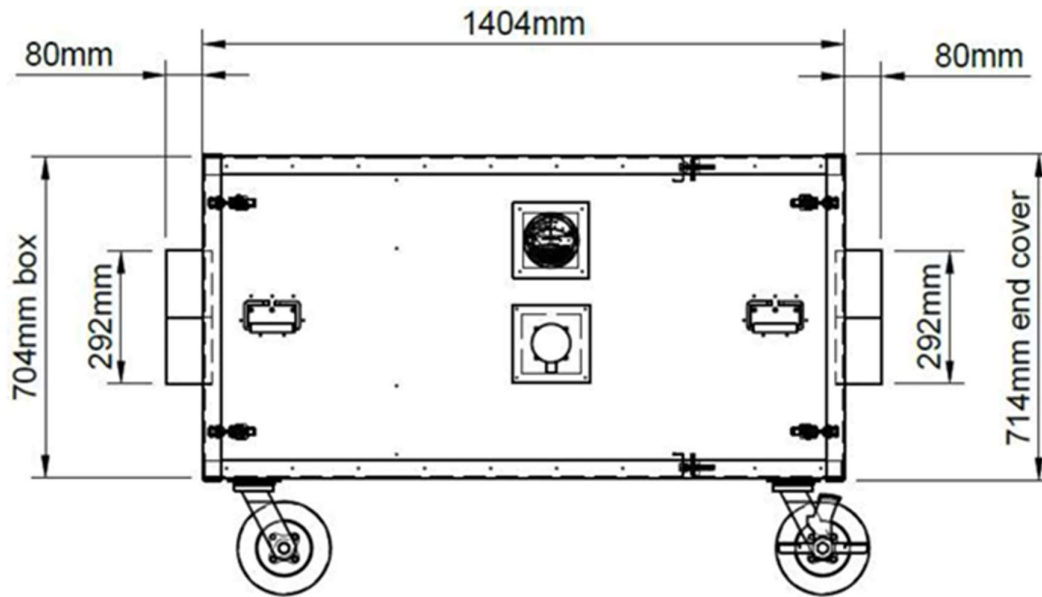

Air Scrubber 5800m³/hr

Max Air Flow:	5800m ³ /hr
Duct Diameter:	305mm
Dimensions LxWxH:	1564 x 714 x 963mm
Weight:	125kg
Lifting Method:	Forklift/Lifting Slings
Filters:	H13 HEPA Filter F9 Secondary Filter F5 Pre-Filter Optional Carbon Fume Filter
Alarms:	Magnahellic Pressure Gauge (100Kpa) Light and Sound

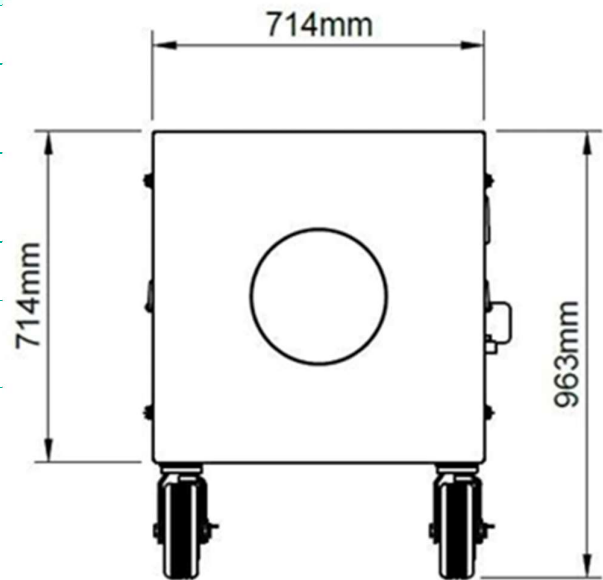

SPECIFICATION SHEET: 300MM CENTRIFUGAL FAN

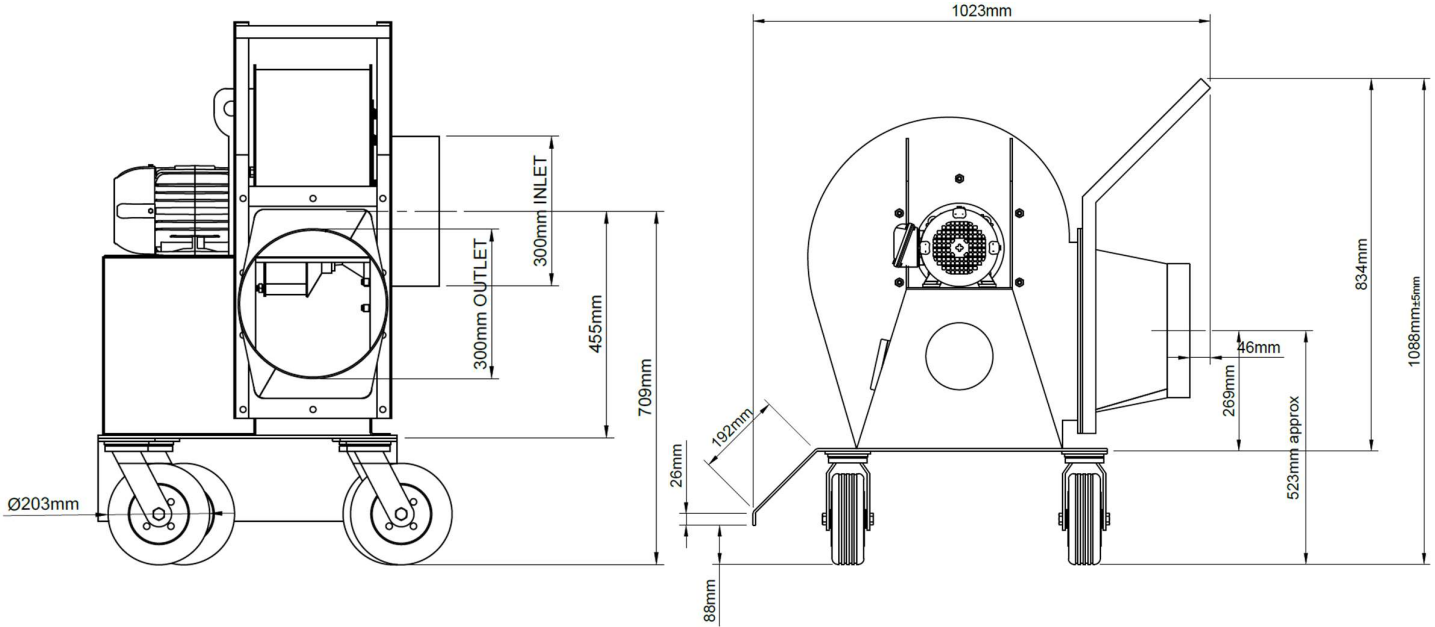

300mm Centrifugal Fan

Fan Curve

Max Air Flow:	6000m ³ /hr
Noise Level:	77dBA @ 1m
Motor:	2.2kW
Power:	415V, 20A
Power Outlet:	3 Phase
Duct Diameter:	305mm
Dimensions (mm):	1023L x 710W x 1088H
Weight:	100kg
Lifting Method:	Forklift/Lifting Slings
Silencer/Attenuator:	Optional

