



Premiere Auditorium

Premiere is a system designed specifically for lecture halls, conference centres, meeting rooms and similar purposes with a perfect combination of modern design, durability, ergonomic comfort and price.



Design
Manufacture
Create



Back and Seat

Back and seat cushions are moulded polyurethane foam with ergonomic design, furnished with various colour of fabric. The polypropylene (PP) back cover with numbering is convenient for audience to locate their seat from behind.



Retractable writing tablet

The tablet can be retracted inside the side panel when not in use. The heavy duty die-cast aluminium structure provides the strength to support an A4 size tablet suitable for laptops, conference binders or others, Pencil and accessories slot specially designed for suit the needs of multitasking audiences.

Seat

Upholstered polyurethane seat with spring return mechanism hidden inside the seat cover. Injection Moulded Polypropylene(PP) seat cover with structural ribs for extra beauty and strength to the seat itself.

Available in

3 Backrest Height

- Executive
- Superior
- Basic

4 Fitting Combinations

- Standard side panel
- With cup holder only
- With writing tablet only
- With cup holder and writing tablet

Standard Features

Back and Seat Numbers

Self-adhesive sticker
Font style is Arial

Seat Mechanism

Auto return seat with spring mechanism

Fixing

Available with floor mounting only

Finishing

Mild steel frame in epoxy powder coating in black colour
Other colour only available upon request

Optional Features

2 Armcap Finishing Options

Standard black colour
Optional beech colour

Aisle Lighting

Light with row label
Row label is Arial



Premiere Executive 543 FD BAC AK

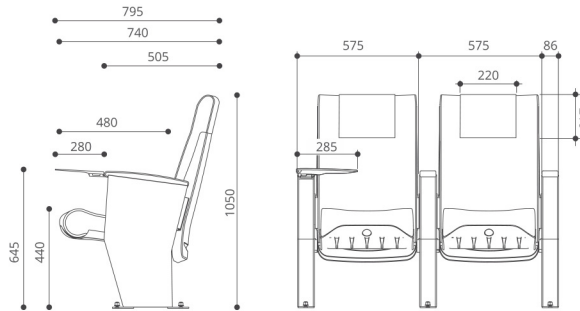

Premiere Basic 541 FD BAC AK

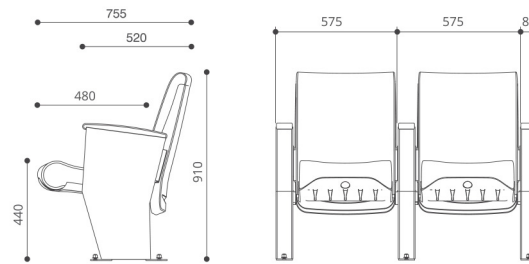

Premiere: Options

Side Panel Fitting:

- Standard Side Panel (BAC)
- With Cup Holder (BCH)
- With Writing Tablet (BWT)
- With Writing Tablet & Cup Holder (BCH)

Armcap Finishing:

- Black Plastic Armcap (B)
- Beech Plastic Armcap (X)

Accessory:

- Aisle Light With Number (AL)

Premiere Superior 542 FD BAC AK

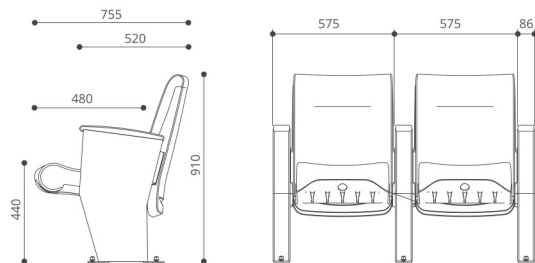

Proposed Installation Guide

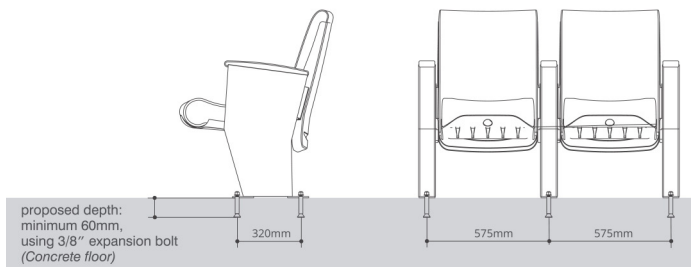

Get In Touch

Sydney Office:

U5 / 19 Unwins Bridge Road,
St Peters NSW 2044
Phone : 02 9517 4093

Melbourne Office:

101 Moray Street,
South Melbourne VIC 3205
Phone : 0429 654 292

Website : www.mn8design.com

Email : sales@mn8design.com