



interstuhl

TWENTYFOURis5 Chair

The TWENTYFOUR was developed specifically to deal with the high loads that come with continuous use. It was developed for long periods of sitting from top (headrest) to bottom (base) and guarantees that you can sit comfortably without tiring at all times.



Design
Manufacture
Create

TF118

Swivel armchair 24h high with seat and backrest topper and adjustable headrest, backrest topper equipped with "Interstuhl" patch as standard, synchronous mechanism, weight adjustment, 5D T-armrests, width, height and depth adjustable, rotatable, foldable



TF117

Swivel armchair 24h high with with seat and backrest topper, front side equipped with "Interstuhl" patch as standard, synchronous mechanism, weight adjustment, 5D T-armrests, width, height and depth adjustable, rotatable, foldable



TF001

Seat and backrest topper set in black with mesh storage bag



The TWENTYFOUR plays to its strengths in 24-hour shift operation, where the strain and associated requirements for work equipment are particularly high. Equipment needs to be functional, of a high quality and durable in order to enable users to concentrate completely on challenging work processes. This requires a professional solution – the TWENTYFOUR.

Features

- Two-zone foam seat for maximum comfort and sitting without tiring
- Optimum hygiene and additional comfort thanks to exchangeable toppers
- 5D multifunctional armrests with adjustable height, width and depth and additional folding function
- Upholstery made from wear-resistant materials
- Robust aluminium base
- Synchronous mechanism
- Recommended for persons up to 150 kg

Certifications

- GS Tested
- BRITISH STANDARD
- BIFMA

Warranty

- 10 years

Materials in Collection

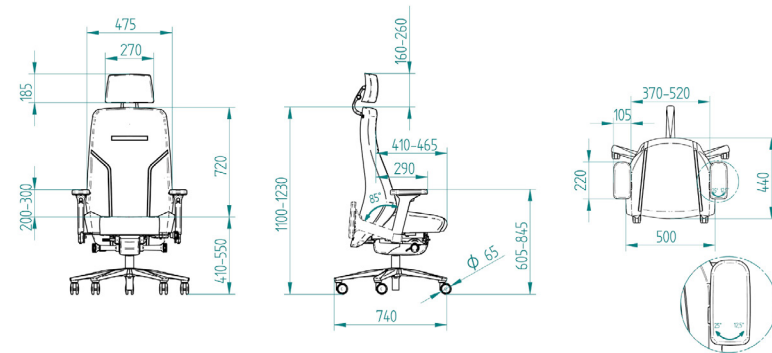
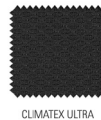

For a complete range of product specifications for TWENTYFOURis5 chairs

Get In Touch

Sydney Office:

U5 / 19 Unwins Bridge Road,
St Peters NSW 2044
Phone : 02 9517 4093

Melbourne Office:

101 Moray Street,
South Melbourne VIC 3205
Phone : 0429 654 292

Website : www.mn8design.com

Email : sales@mn8design.com