

Wilde + Spieth



S 197 R20 Swivel Chair



Design
Manufacture
Create

A contemporary evolution of the classic SBG 197 R Swivel Chair, the S 197 R20 Swivel Chair achieves the highest ergonomic credentials. While distinct in its form, S 197 R20 is functionally equivalent to its predecessor—borrowing the seat and backrest of Eiermann’s classic SE 68 and adding a unique floating tilt mechanism that allows each to move independently from the other. Configured with an adjustable backrest height, seat height, and seat tilt, the chair can be optionally customised with upholstery or armrests. S 197 R20 is available in two heights, with or without a circular footrest, and with soft or hard double castors, suitable for solid wood flooring or carpet respectively. Please specify your preference for each feature when ordering.



Specifications

Frame

- Swivel chair with aluminium frame, casters.

Seat and Backrest

- Moulded seat and backrest of laminated wood veneer.

Adjustability

- Seat: height adjustment, tilt adjustment.
- Backrest: height adjustment, tilt adjustment.

Castors

- 70 mm plastic casters soft for hard floors or hard for carpet.

Options

- Beech Armrests, counter model with foot rest, upholstery, chrome casters for hard floors or soft for carpet, glides instead of casters.

Weight

- Approx 10 kg.

Measurements (in cm)

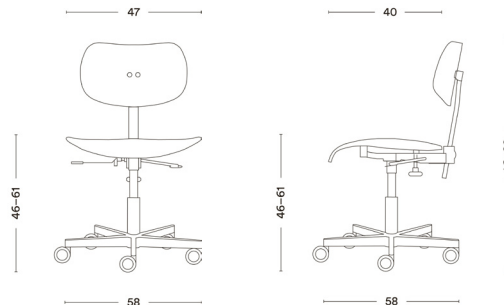

Colours

Frame



Chrome



Matte Black

Seat and Backrest



Beech (clear coated)



Oak (clear coated)



Ash (clear coated)



Walnut (clear coated)



Black

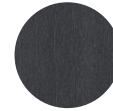

Graphite



Cobalt Blue



Blood Orange



Yellow



Rosé



Light Grey



Black (lacquered)



White (lacquered)

Upholstery



Topia by Rohi



Novum by Rohi



Extreme by Camira



Advantage by Camira



Synthetic Leather

Custom-made

- Special colours, fabrics, leather and synthetic leather on request.

Get In Touch

Sydney Office:

6 - 10 Phillips Road,
Kogarah NSW 2217
Phone : 02 9517 4093

Melbourne Office:

101 Moray Street,
South Melbourne VIC 3205
Phone : 0429 654 292

Website : www.mn8design.com

Email : sales@mn8design.com