

Wilde + Spieth



SE 68 Multi Purpose Chair



Design
Manufacture
Create

Designed by Egon Eiermann, 1949

As the first piece of furniture jointly developed by Egon Eiermann and Wilde + Spieth, the SE 42 3-Legged Chair distinguishes itself with a unique three-legged frame consisting completely of moulded wood—a complex design that, together with Eiermann's aspiration to keep the bending radius of the seat front to a minimum, challenged the limits of the production techniques upon realisation. Seventy years after its first appearance, the chair stands its ground as a modern classic with its fluid curves and assured stature. SE 42 is available in natural beech and stained black.

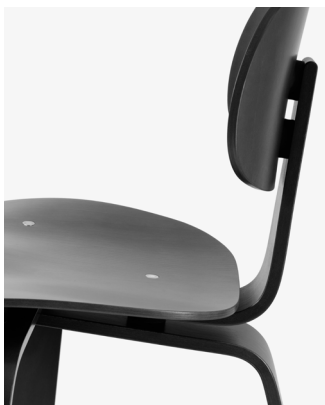

Specifications

Frame

- 3-legged curved wooden chair with contoured wooden frame.

Seat and Backrest

- Three-dimensionally moulded seat with backrest of laminated beech veneer.

Options

- Armrests, upholstery, silence glides of felt or Teflon.

Weight

- Approx 5.0 kg.

Measurements (in cm)

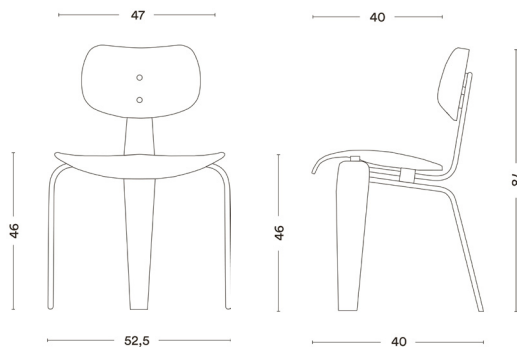

Colours



Beech (clear coated)



Stained Black

Custom-made

- Special colours on request.



Get In Touch

Sydney Office:

6 - 10 Phillips Road,
Kogarah NSW 2217
Phone : 02 9517 4093

Melbourne Office:

101 Moray Street,
South Melbourne VIC 3205
Phone : 0429 654 292

Website : www.mn8design.com

Email : sales@mn8design.com