

Wilde + Spieth



SE 68 SU Stackable Chair



Design
Manufacture
Create

As the stackable version of the iconic SE 68, the SE 68 SU Stackable Chair has become the seating solution of choice for row seating within the world's greatest cultural institutions, appreciated for balancing discretion with undeniable presence. Distinguished from the SE 68 in its slightly smaller seat and the differing incline of its legs, SE 68 SU seamlessly adapts to suit the characteristics of diverse interiors, appearing as though individually designed for each environment. In doing so, it lends an expressiveness that transforms every room's composition into one of harmonious unity. SE 68 SU can be customised with upholstery, armrests, and a row-linking system on request.



Specifications

Frame

- 4-legged tubular steel frame (Ø 18 × 2 mm), plastic glides.

Seat and Backrest

- Moulded seat and backrest of laminated wood veneer.

Stackability

- Stackable with stacking rubber pads under seat, 8 chairs stackable, with armrests max. 4 chairs stackable.

Options

- Stable row links, beech armrests, added upholstery, silence glides of felt or Teflon, floor protection glides in natural rubber for stone and parquet.

Weight

- Approx 5.0 kg.

Measurements (in cm)

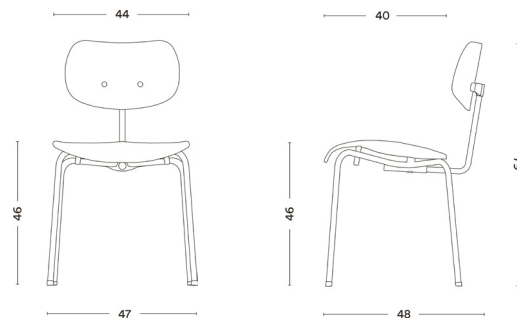

Colours

Frame



Chrome



Matte Black

Seat and Backrest



Beech (clear coated)



Oak (clear coated)



Ash (clear coated)



Walnut (clear coated)



Black



Graphite



Cobalt Blue



Blood Orange



Yellow



Rosé



Light Grey



Black (lacquered)



White (lacquered)

Upholstery



Topia by Rohi



Novum by Rohi



Extreme by Camira



Advantage by Camira



Synthetic Leather

Custom-made

- Special colours, fabrics, leather and synthetic leather on request.

Get In Touch

Sydney Office:

6 - 10 Phillips Road,
Kogarah NSW 2217
Phone : 02 9517 4093

Melbourne Office:

101 Moray Street,
South Melbourne VIC 3205
Phone : 0429 654 292

Website : www.mn8design.com

Email : sales@mn8design.com