



klaro industrial
design

SCORE - PUFFY - MR SCREEN - GLEE



Design
Manufacture
Create

SCORE



Score workstation screens employ simple principle of scoring or slicing panel material to allow it to flex and bend to user's needs.

Screen's flex also allows it to be taller and stiffer (think English wavy singe brick wall), compared to flat upright panel.

House shapes are a cost-effective option, as sheet is utilised to its maximum capacity, however custom solutions also available on request

Please note - location of scored section is determined by size of desktop and its radius.



Specifications

Flame Retardant: EN 13501
 Acoustics: EN ISO 354:2003
 Weight Range: 1300g/m²-3500g/m²
 Eco-friendly: AS/NZS 4266 recycled PET staple fibre no chemical irritants free of harmful substances.

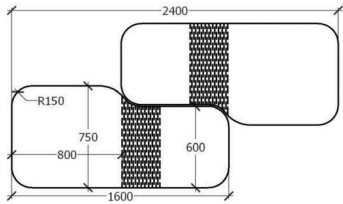

WINGS 12mm - Set of 2

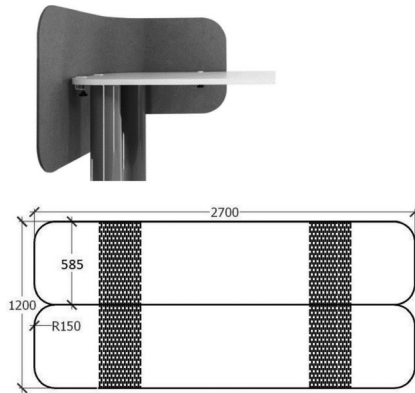

DOUBLE RETURN 12mm - Set of 2

SINGLE RETURN 12mm - Set of 2

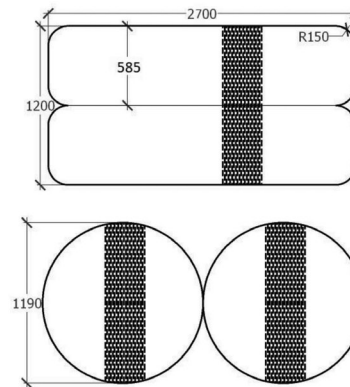

CIRCLE 12mm - Set of 2

DOUBLE RETURN 12mm - Set of 4

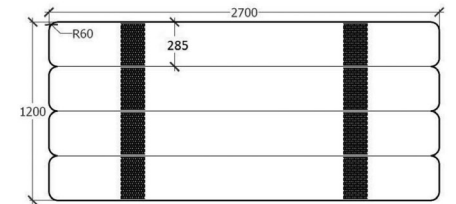

All sizes shown in millimetres.

Colours

Colour variation of approx. 5%



Hardware

GRIP

Suitable for use with 12mm to 17mm thick panel. Heavy duty tape installation to desk top surface to avoid drill holes.

White or black powder coat colours in stock. MTO - Dulux or Interpon standard powder coat colour ranges.

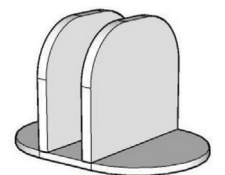

CLAMP

Suitable for use with 12mm to 17mm thick panel and 25-33mm thick desktop no drill holes required. MTO - Dulux or Interpon standard powder coat colour ranges.

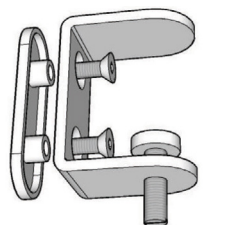

PUFFY

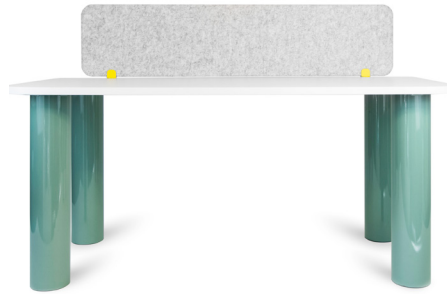

Hot compression mould method is used to achieve stiff double layered 17mm thick pre-formed pinnable PET panel that equally effective used as a dividing screen or a desk modesty panel

Subtle touch of relief, achieved by using our unique moulds, adds interest but does not allow itself to interfere with surrounding interior



Specifications

Flame Retardant: EN 13501

Acoustics: EN ISO 354:2003

Weight Range: 1300g/m²-3500g/m²

Eco-friendly: AS/NZS 4266 recycled
PET staple fibre, with no chemical
irritants, free of harmful substances.

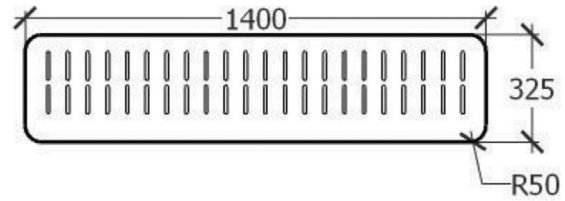
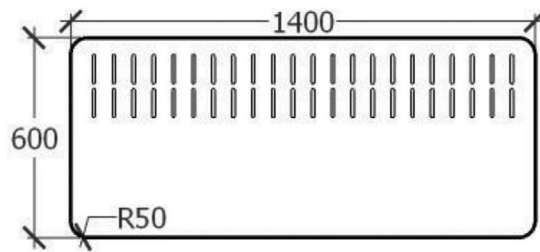

All sizes shown in millimetres.

Colours

Colour variation of approx. 5%



MR SCREEN

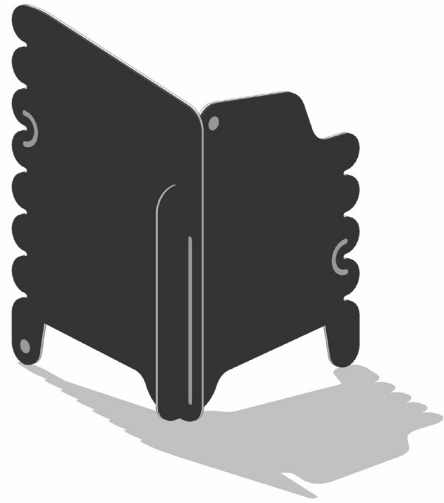

Mr. SCREEN is a portable and collapsable acoustic screen. The design has been optimized to use only one 2700 x 1200 acoustic panel of each color. The on-demand lightweight sound and visual privacy is available in our house range of 70% recycled PET acoustic panel colors, as listed below, or any other suitable acoustic panel to specification.



Colours

Colour variation of approx. 5%



BZ04



BZ11

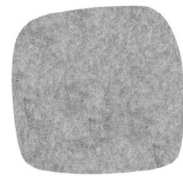

BZ20



BZ36



BZ37

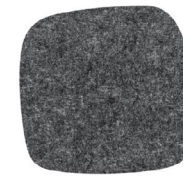

BZ03

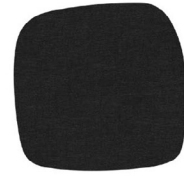

BZ13



BZ12

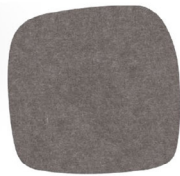

BZ15



BZ02

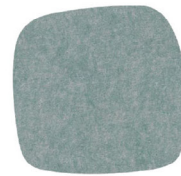

BZ18

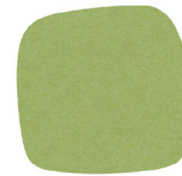

BZ43

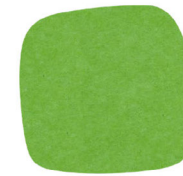

BZ51

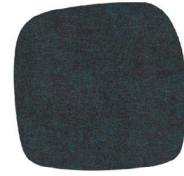

BZ17



BZ28

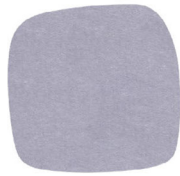

BZ30



BZ14

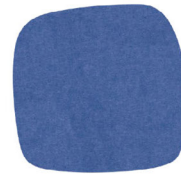

BZ25

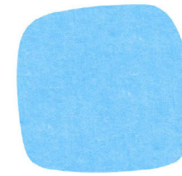

BZ27

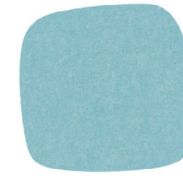

BZ23



BZ16



BZ46

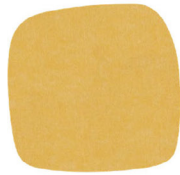

BZ05

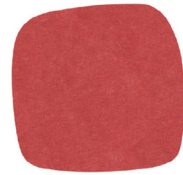

BZ08

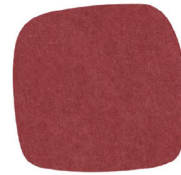

BZ24



BZ60



BZ50



BZ101

GLEE



GLEE range is developed to bring uncomplicated and cost-effective solution, where decorative effect is required, while offering acoustic, visual, and physical barrier properties. 9mm and 12mm post-consumer PET fibre panel is cut to shapes using precision CNC technology.

Glee is fully pinnable and is available in optimised format to reduce wastage.

Kits are suitable for wall application, workstation screens, ceiling and hanging installation.

We recommend good quality web adhesive for wall application, conventional hardware will work for desktop, ceiling, or suspended installation.

Custom shapes are also available, please enquire – we love a challenge.



Specifications

4 x 2 - 12mm

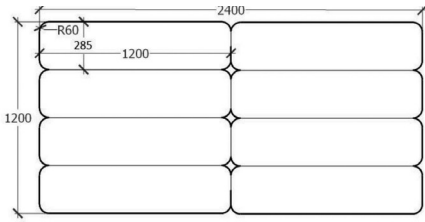

4 x 1- 24mm

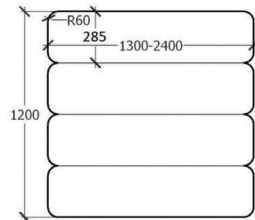

2 x 2- 12mm

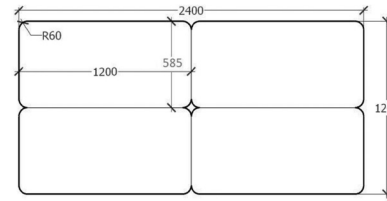

2 x 1- 24mm

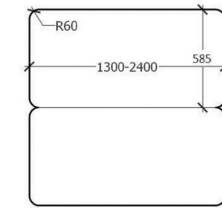

3 x 2 - 12mm

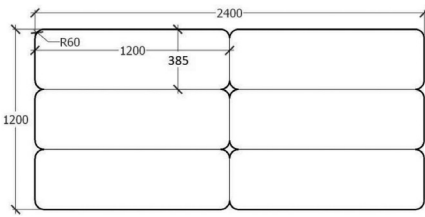

3 x 1- 24mm

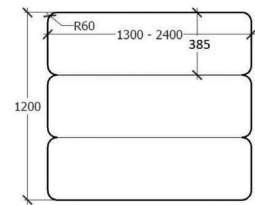

Slide on territory
4 x circles 12mm, 24mm

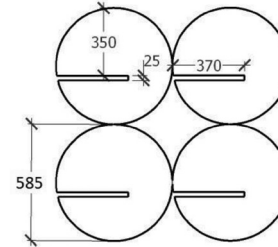

Slide on territory
4 x rectangles 12mm, 24mm

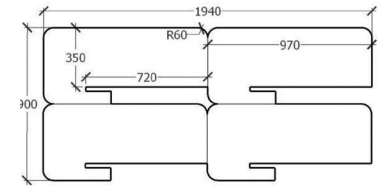

HONEY quarter sheet usage 9, 12, 24mm

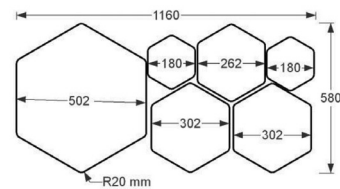

SQUARE quarter sheet usage 9, 12, 24mm

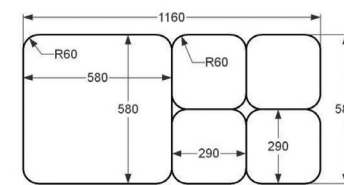

CIRCLE quarter sheet usage 9, 12, 24mm

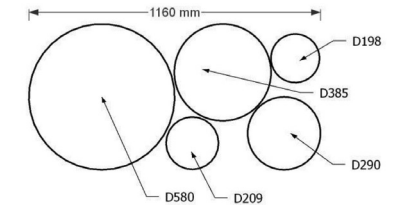

ARROWS half sheet usage 9, 12, 24mm

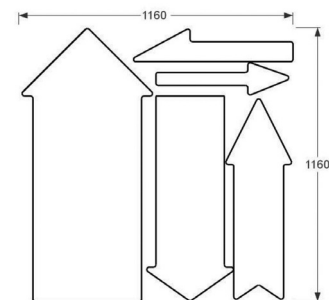

MONSTERA half sheet usage 9, 12mm

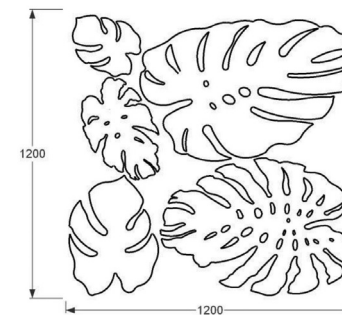

DONUT half sheet usage 9, 12, 24mm

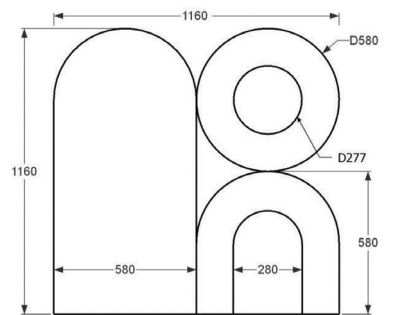

Colours

Colour variation of approx. 5%



Hardware

GRIP

Suitable for use with 12mm to 17mm thick panel
Heavy duty tape installation to desk top surface to avoid drill holes.

White or black powder coat colours in stock.
MTO – Dulux or Interpon standard powder coat colour ranges.

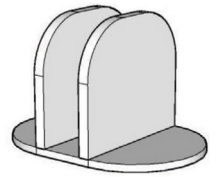

CLAMP

Suitable for use with 12mm to 17mm thick panel and 25-33mm thick desktop no drill holes required.
MTO – Dulux or Interpon standard powder coat colour ranges.

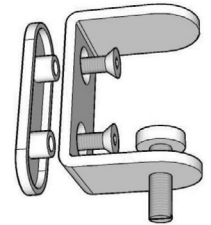

Flame Retardant: EN 13501

Acoustics: EN ISO 354:2003

Weight Range: 1300g/m²-3500g/m²

Eco-friendly: AS/NZS 4266 recycled PET staple fibre no chemical irritants free of harmful substances.

Get In Touch

Sydney Office:

6 - 10 Phillips Road,
Kogarah NSW 2217

Melbourne Office:

101 Moray Street,
South Melbourne VIC 3205

Call 1300 362 628

Website : www.mn8design.com

Email : sales@mn8design.com