

KPM FUEL SYSTEMS

2007-2009 PONTIAC G8 & 2013-2017 CHEVROLET SS 1500HP FUEL MODULE





Important! Must Read First

Congratulations on the purchase of a KPM Fuel System for your [2007-2009 Pontiac G8](#) or [2013-2017 Chevrolet SS](#).

To ensure your fuel system is fitted correctly and operates perfectly and reliably, we advise that this kit is fitted by a KPM Fuel Systems Dealer workshop.

If you are unable to access a KPM Fuel Systems dealer, we **strongly** recommend a professional and experienced fully qualified technician to install your new fuel system.

Ask your qualified installer to contact KPM Fuel Systems on any aspect unclear in the instructions provided.

Email: support@kpmfuelsystems.com

As a wide variety of skills, procedures, special tools, and workshop equipment is needed to install this kit:

- KPM will take NO responsibility or give NO guarantees on the operation of this product for fitment not carried out by a KPM Fuel Systems dealer or experienced qualified technician.
- KPM will take NO responsibility or give NO guarantees on the operation of this product due to not fitting this kit exactly as per the instructions provided.
- Ensure correct workshop safety procedures are carried out in fitment of this kit.
- Please read **ALL** instructions before commencing fitment

Guarantee

On satisfaction that **ALL** instructions have been followed as per this document KPM will warrant this KPM Fuel System against any defects or faults for 12 months from the date of purchase.



Important

This fuel system is engineered to operate perfectly as a complete system when used with all components as supplied only by KPM Fuel Systems.

Depending on the level of KPM Fuel System you have purchased, included in the kit will be the following;

- 1) KPM Fuel Module x 1 – Primary (for increased flow and capacity)
 - 2) KPM Plug and Play Wiring/relay kit (for correct and reliable current supply)
 - 3) [Pontiac G8 Retrofit Kit \(2007-2009 models only\)](#).
- KPM Fuel Systems will take NO responsibility for the operation of this fuelsystem if any of the components listed are not utilized with this package.
 - KPM Fuel Systems will take NO responsibility for the operation of this fuel system if any of the components listed are replaced with a non-KPM approved component.
 - KPM will take NO responsibility for the operation of this fuel system if used on a vehicle NOT fully retrofitted for E85 Ethanol or flex fuel.

[Note: E85 Ethanol is highly corrosive on many components.](#)

Please be aware that if your car is NOT built for E85 Ethanol from manufacturer, it may be possible that components [NOT](#) supplied by KPM Fuel Systems will also need to be replaced or suited for E85 Ethanol. Examples of some possible non-compatible components - are fuel injectors, fuel filters, fuel lines, rubber hoses, fittings etc.

[All KPM Fuel System components are 100% Ethanol and Gasoline compatible](#)



Before Dismantling

- You will need to reduce residual fuel pressure in the fuel system to 0 kPa to enable disconnection of fuel lines.
- You can do this by removing the fuel pump fuse and running the engine until fuel pressure drops to 0 kPa.
- Disconnect the Battery.

Standard Fuel Module Removal

- 1) Drain fuel tank.
- 2) The vehicles fuel tank needs to be removed to access the in-tank fuel module. You will need to remove the fuel tank from your vehicle as per the manufacturer's instructions.
- 3) Remove the fuel lines from the fuel module (a quick disconnect tool is recommended for disconnecting fuel lines, take extra care in not crimping/damaging the fuel line on removal). Remove the electrical connectors from the module. [FIGURE 1](#)
- 4) Remove the retaining ring holding the fuel module to the tank with the correct tool. [FIGURE 2](#)
- 5) Lift the fuel module from the tank until you can access and remove the crossover pipe connector at the base of the canister.
- 6) Carefully lift the fuel module completely from the fuel tank. [FIGURE 3](#)

KPM FUEL SYSTEMS

FIGURE 1

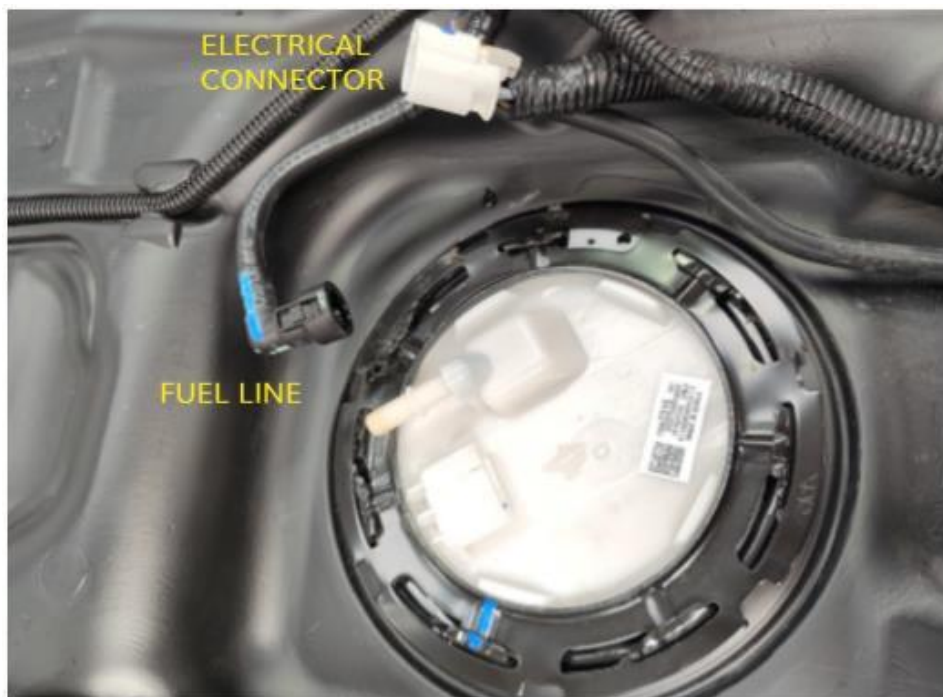
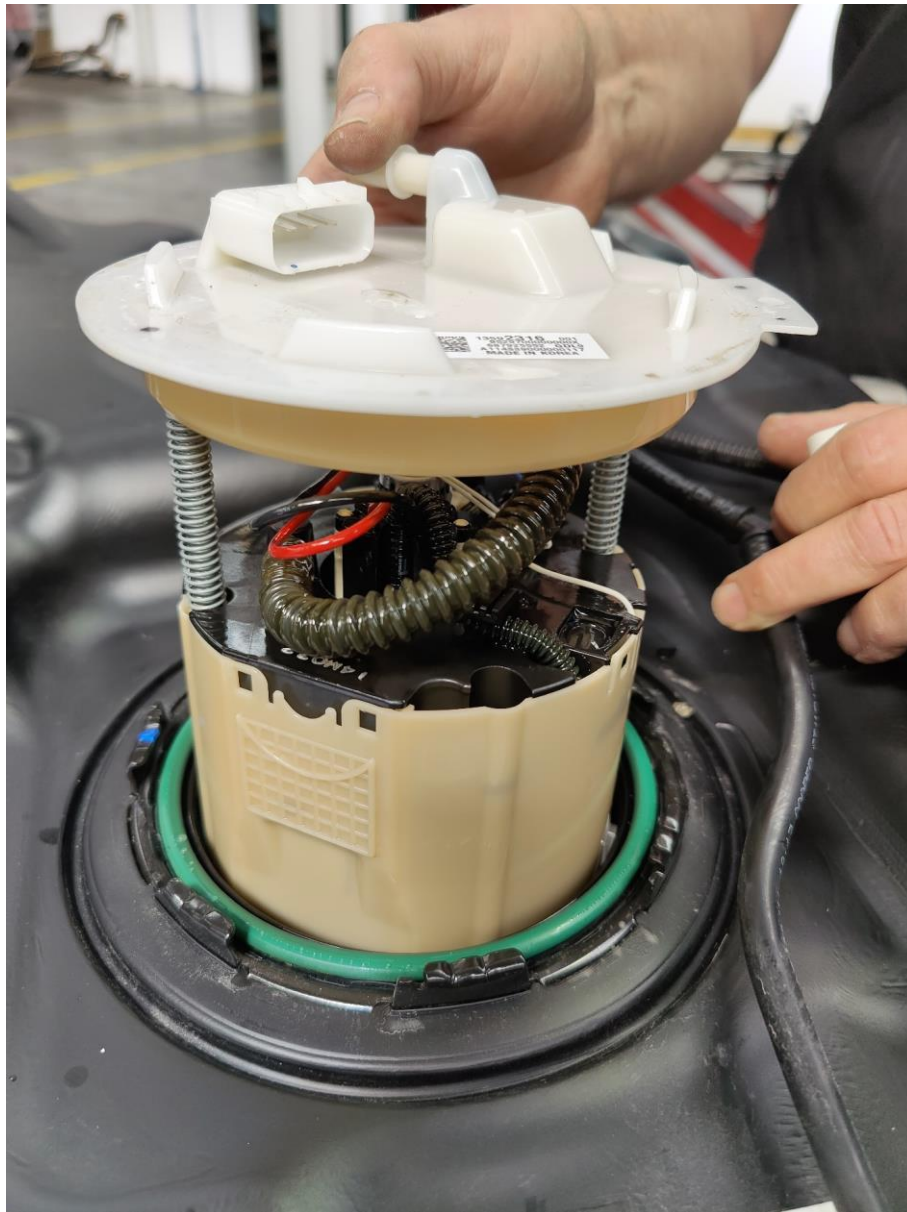

FIGURE 2



FIGURE 3





KPM Primary Fuel Module Fitment 1500HP

If your vehicle is a 2007-2009 Pontiac G8, you will need to fit the Retrofit Kit supplied as per the supplementary instructions provided.

If your vehicle is a 2013-2017 Chevrolet SS, you will need to remove the Fuel Sender Unit from the standard fuel module, for fitment to the upgraded KPM Fuel Module.

- 1) Carefully lower the new fuel module into the tank taking care not to damage the fuel sender and float mechanism while doing so.
- 2) Ensure that you can access the crossover pipe connector in the fuel tank with plenty of room to reconnect to the base of the canister.
- 3) Ensure the crossover pipe connector clicks fully onto the fuel pump module canister.
- 4) Retention the retaining ring to secure the fuel module into the tank with the correct tool.
 - Ensure module is sitting square and flush on the seal prior to tensioning.
- 5) Refit fuel lines ensuring they have clicked on properly.
 - Take extra care in not crimping/damaging the fuel line on removal or replacement.
- 6) Proceed to refit the remainder of your fuel tank as per manufacturer's instructions.
- 7) Be sure to read the [wiring fitment instructions](#) in the next section prior to re-fitting the fuel tank.

Wiring/Relay Fitment (Schematic Diagram Attached)

IMPORTANT INFORMATION

Due to the two Bosch Racing fuel pumps fitted to the KPM1500HP fuel module, the vehicles Fuel System Control Module (FSCM) is bypassed with this wiring kit.

This is due to the fuel pumps drawing an increased amperage much higher than the (FSCM) is designed for. Should you want to retain the OE fuel pressures and control that the FSCM offers, you will need the additional KPM PWM Fuel Control Module Kit.

Pontiac G8 2007-2009 Part # S-COMPWM1500-K

Chevrolet SS 2013-2017 Part # S-COMPWM1500

Sedan

- 1) Remove the base of the rear seat from the vehicle cabin.
- 2) Locate rubber grommet for fuel pump wiring on the RH floor area.
- 3) Pop out the rubber grommet to make provision to feed the new fuel pump wiring loom through.
- 4) See below:
 - a. **2007-2009 Pontiac G8**– A new 50mm grommet is supplied with the wiring loom #Com3.
 - b. **2013-2017 Chevrolet SS**– You will need to modify the grommet by using a 24mm hole punch to accept the new 24mm grommet and loom #Com3.



KPM FUEL SYSTEMS

- 5) Feed the new #Com3 wiring loom through the floor, and fit the correct supplied grommet in position. This will allow the undercar side of the loom to hang under the vehicle ready to connect on the fuel tank fitment.
- 6) From in the cabin, follow the factory loom around to the LH side of the rear seat.



- 7) Locate the gap between the rear seat and body area to be able to feed the new loom sections #Com1 & #Com2 into the trunk toward the battery.



- 8) Mount the supplied relay securely on an appropriate surface and secure the loom.
- 9) Attach the loom wires to the battery as per the circuit diagram below.
- 10) Ensure the rubber grommet is in position and fitted correctly.



- 11) Refit the rear seat base to vehicle.
- 12) You will now have the remainder of the new loom connectors hanging down into your fuel tank cavity area. These connectors will require re-connection to your factory loom and new fuel module on re-fitment of the fuel tank.
 - a. Be sure to connect the earth wire eyelet to the new fuel module earth stud by securing the supplied nut and washer.
- 13) Proceed to fit the remainder of your fuel tank as per manufacturer's instructions.

#COMWIRE1500

Chevrolet SS 2013-2017

Pontiac G8 2007-2009

Wiring Schematics

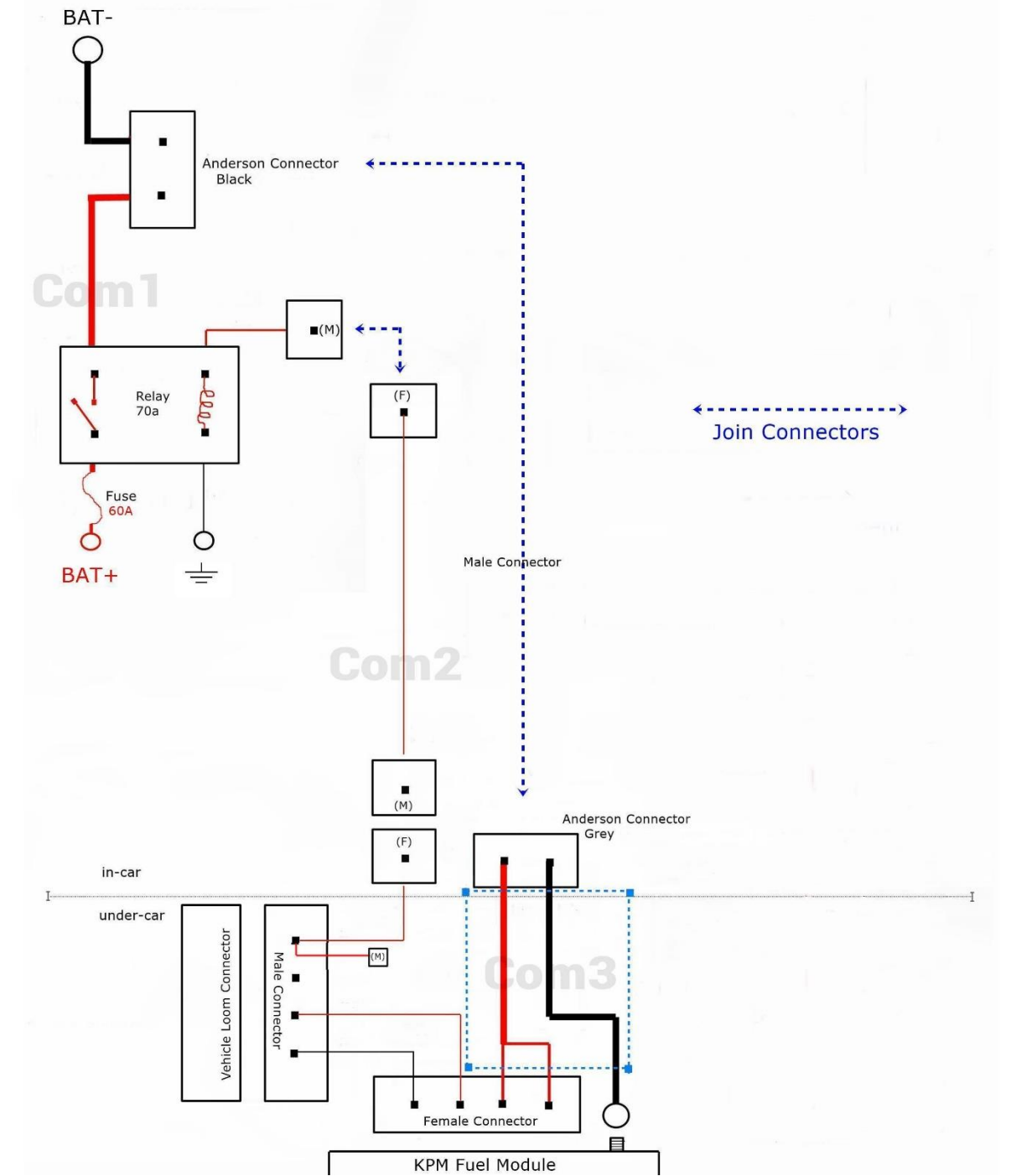

2007-2009 Pontiac G8 Models

For 2007-2009 Pontiac G8 models, you will need to have a tuning professional adjust the following tables in your software to run the system correctly.

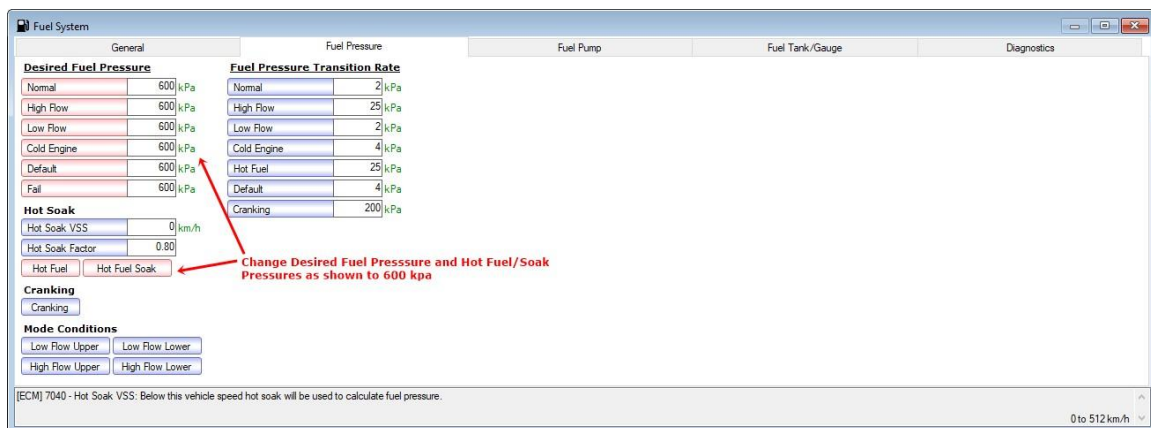
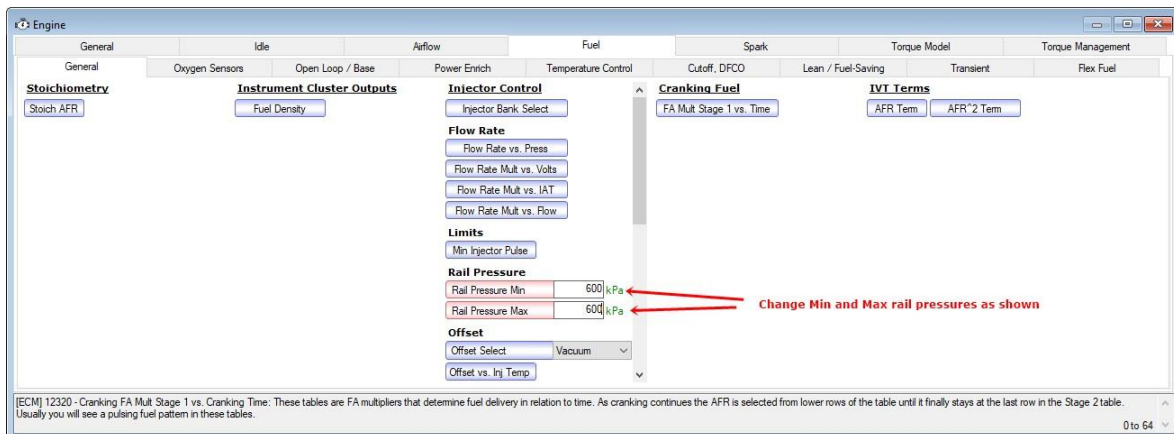

System Software Re-Calibration (cont'd)

2013-2017 Chevrolet SS Models

For 2013-2017 Chevrolet SS', you will need to have a tuning professional check and adjust the following tables in your engine software to run the system correctly.

Note The Chevrolet SS runs a Fuel System Control Module (FSCM) to run the fuel pumps.

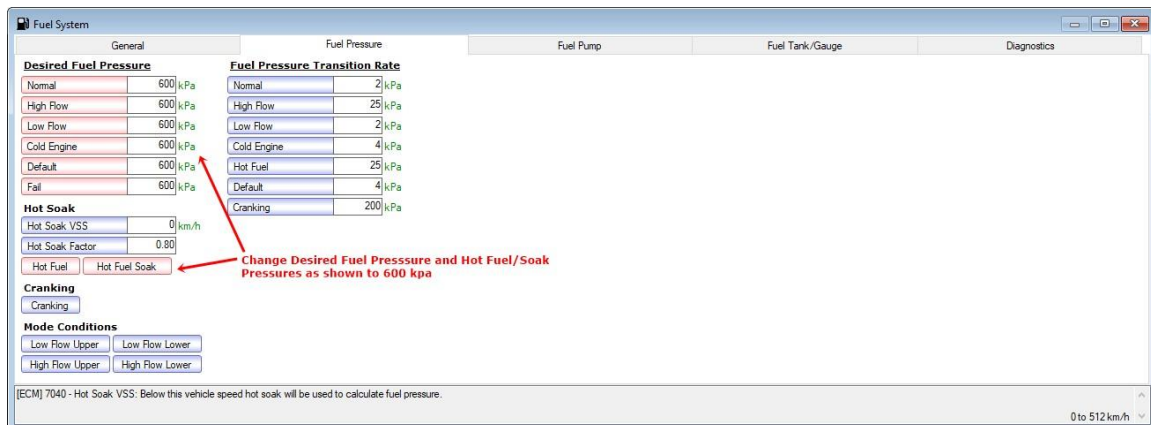
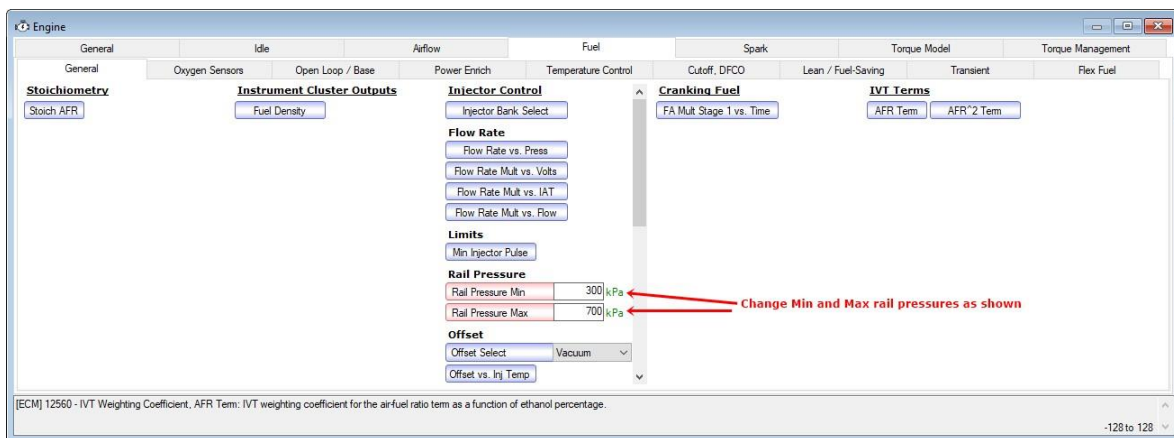



Engine Start Up

- 1) Refit the fuel pump fuse.
- 2) Reconnect your battery.
- 3) Ensure you have at least ½ tank of correct clean/fresh fuel.
- 4) Connect a fuel pressure gauge to the supply line at the fuel rail or read your fuel pressure on your scan tool.
- 5) Prime fuel system and start engine.
- 6) Check all fittings at pump and fuel rail for **NO** leaks
- 7) Check pressures are within specifications below.

If not within the specifications below, you will need to check for correct fitment and take the normal course of diagnosis to rectify before proceeding.

Fuel Pressure engine idling 575-600 Kpa

- 8) Stop engine and relieve fuel pressure.
- 9) Remove fuel pressure gauge and refit fuel line.
- 10) Re-start engine and check for NO leaks.

IMPORTANT INFORMATION

As we test every module before it is shipped, we have operating pressures recorded for each specific part number.

| Part Number | Idle Pressure (Max Pressure) | Full Load Pressure (Min Pressure) |
|-------------------|---------------------------------|--------------------------------------|
| KPMCOM1500 | 570-600 kPa | 350 kPa |

As these pressures are the base operating pressure in the testing station, they can be used directly into the vehicle's calibration.

However, as we have found minor variances from vehicle to vehicle, it is recommended to manually check pressures on vehicle when able to do so, preferably at the fuel rail and use observed pressure to populate tables in the calibration. These should be the same or extremely close to testing pressure.

All KPM fuel modules listed have been manufactured and designed to run at the listed pressures at idle and light cruise. They have also been designed to **decrease** the fuel pressure while applying engine load for **increased** fuel demand.

This is how the system is designed to perform and is absolutely what you will expect to see while logging fuel pressures on road or dyno.

All KPM Fuel Modules are designed to perfectly supply fuel down to a minimum pressure of 350kpa at full demand for its power rating.

KPM Fuel Systems strongly recommends that you have your engine tune checked by a professional tuning workshop!

Depending on the previous fuel system your vehicle has been tuned to, your car may run differently with the new KPM Fuel System pressure and extra supply.

This can cause rich or lean fuel mixtures and possibly be detrimental to your engine!

It is your responsibility to have your vehicle checked and/or re-tuned by specialist methods to ensure correct fueling and engine safety and reliability.

It is your responsibility to have your vehicle checked and/or re-tuned by specialist methods to ensure any fault codes in the vehicles electronic management system/s are corrected.