

Mixed Species Plantation Oak (Eucalyptus nitens; Eucalyptus grandis)

Speak to an expert:
 1300 792 519
www.cusp.com.au

The information and calculations contained within this Guide are for the properties of Cusp 13 beams only. Other manufacturers may have different properties, and may have used different calculation methods, and therefore cannot be designed using the span tables presented herein.

These span tables are to be used for a preliminary design only and does not replace the need for a qualified engineer to conduct a full static calculation to confirm Cusp 13 beams sizing.

These span tables have been designed in accordance with the following codes:

- AS 1170.0, .1, .2:2002 Loading Codes for Limit State design, Live Loads, and Wind Loads respectively.
- AS 1720.1:2010 Timber Structures - Part 1: Design Methods.
- AS 1720.3:2016 Timber Structures - Part 3: Design criteria for timber-framed residential buildings.
- AS 1684:1999 - Residential timber framed construction - Part 2-5.
- AS/NZS 1328.1:1998 Glued laminated structural timber - Part 1: Performance requirements and minimum production requirements.

These span tables have been prepared following design methods and loads prescribed in:

- AS 1720.1:2010 Timber Structures - Part 1: Design Methods.
- AS1720.3:2016 Timber Structures - Part 3: Design criteria for timber-framed residential buildings.
- Floor mass up to 40 kg/m².
 Live loads of 150 kg/m².

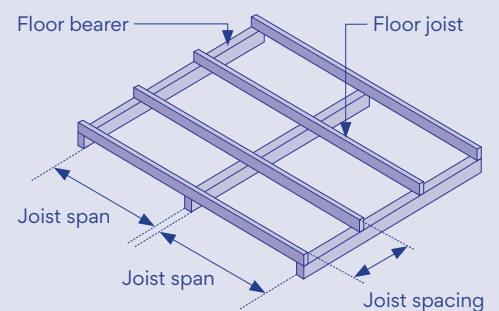

GLT Maximum Single Span 13 Joists Mixed Species Plantation Oak (Eucalyptus nitens; Eucalyptus grandis)

Cross-section dimensions	Joist Spacing (mm)						
	W(mm) x D(mm)	300	350	400	450	500	550
45 x 140	3800	3700	3500	3400	3300	3200	3100
45 x 190	4800	4600	4500	4300	4200	4100	4000
45 x 240	5700	5500	5300	5200	5000	4900	4800
45 x 294	6600	6400	6200	6000	5800	5700	5600
65 x 140	4200	4000	3900	3800	3700	3600	3500
65 x 190	5200	5100	4900	4700	4600	4500	4400
65 x 240	6300	6000	5800	5700	5500	5400	5300
65 x 294	7300	7000	6800	6600	6400	6300	6100
65 x 336	7900	7700	7500	7300	7100	6900	6800
65 x 360	8300	8100	7900	7700	7500	7300	7100
65 x 400	8900	8700	8500	8300	8100	7900	7700
85 x 294	7600	7400	7200	7000	6900	6700	6500
85 x 336	8300	8100	7900	7800	7600	7400	7200
85 x 360	8700	8500	8300	8100	8000	7800	7600
85 x 400	9300	9100	8900	8700	8600	8400	8200

GLT Maximum Continuous Span 13 Joists Mixed Species Plantation Oak (Eucalyptus nitens; Eucalyptus grandis)

Cross-section dimensions	Joist Spacing (mm)						
	W(mm) x D(mm)	300	350	400	450	500	550
45 x 140	4700	4600	4400	4300	4200	4100	4000
45 x 190	6000	5700	5600	5400	5200	5100	5000
45 x 240	7100	6800	6600	6400	6300	6100	6000
45 x 294	8300	8000	7700	7500	7300	7100	7000

GLT Maximum Continuous Span 13 Joists Mixed Species Plantation Oak (Eucalyptus nitens; Eucalyptus grandis)

Cross-section dimensions	Joist Spacing (mm)						
	300	350	400	450	500	550	600
W(mm) x D(mm)							
65 x 140	5200	5000	4800	4700	4600	4500	4400
65 x 190	6500	6300	6100	5900	5800	5600	5500
65 x 240	7800	7500	7300	7000	6900	6700	6600
65 x 294	9000	8700	8400	8200	8000	7800	7600
65 x 336	9900	9600	9300	9100	8800	8600	8400
65 x 360	10400	10100	9800	9500	9300	9100	8900
65 x 400	11100	10800	10600	10300	10100	9800	9600
85 x 294	9500	9200	9000	8800	8500	8300	8200
85 x 336	10300	10100	9900	9700	9400	9200	9000
85 x 360	10800	10600	10300	10100	9900	9700	9500
85 x 400	11600	11300	11100	10900	10700	10500	10300

Notes

- W = member width, D = member depth.
- The values presented above were obtained based on the following assumptions:
 - Permanent loads: Floor mass up to 40 kg/m² + self-weight + 0.5 KPa of the live load
 - Live loads: Floor live load of 1.5 kPa
 - Structural models and load combinations as per AS 1720.3 - Section 4.1 Floor Joists $\phi=0.95$
 - Load duration factor $k_1=0.57, 0.8$ and 0.94 for load categories 1, 2 and 3 respectively.
 - Modification factors for strength $k_4, k_7, k_9, k_{12}, k_{16}=1.0$
 - Modification factors for serviceability (deflections): $j_2=2.0$ for permanent loads and $j_2=1.0$ for transient loads.
 - Serviceability Limits: $L/300$ or 15mm for permanent loads, and $L/360$ or 9mm for transient loads.

Cusp 13 Beams - Span Tables for Bearers supporting floor joists only

Cross-section dimensions	Joist Spacing (mm)						
	W(mm) x D(mm)	300	350	400	450	500	550
65 x 140	5200	5000	4800	4700	4600	4500	4400
65 x 190	6500	6300	6100	5900	5800	5600	5500
65 x 240	7800	7500	7300	7000	6900	6700	6600
65 x 294	9000	8700	8400	8200	8000	7800	7600
65 x 336	9900	9600	9300	9100	8800	8600	8400
65 x 360	10400	10100	9800	9500	9300	9100	8900
65 x 400	11100	10800	10600	10300	10100	9800	9600
85 x 294	9500	9200	9000	8800	8500	8300	8200
85 x 336	10300	10100	9900	9700	9400	9200	9000
85 x 360	10800	10600	10300	10100	9900	9700	9500
85 x 400	11600	11300	11100	10900	10700	10500	10300

These span tables have been prepared following design methods and loads prescribed in:

- AS 1720.1:2010 Timber Structures - Part 1: Design Methods.
- AS1720.3:2016 Timber Structures - Part 3: Design criteria for timber-framed residential buildings.
- Floor mass up to 40 kg/m². Live loads of 150 kg/m².

Notes

- W = member width, D = member depth.
- The values presented above were obtained based on the following assumptions:
 - Permanent loads: Floor mass up to 40 kg/m² + self-weight + 0.5 KPa of the live load
 - Live loads: Floor live load of 1.5 kPa
 - Structural models and load combinations as per AS 1720.3 - Section 4.1 Floor Joists $\Phi=0.95$
 - Load duration factor $k_1=0.57, 0.8$ and 0.94 for load categories 1, 2 and 3 respectively.
 - Modification factors for strength $k_4, k_7, k_9, k_{12}, k_{16}=1.0$
 - Modification factors for serviceability (deflections): $j_2=2.0$ for permanent loads and $j_2=1.0$ for transient loads.
 - Serviceability Limits: $L/300$ or 15mm for permanent loads, and $L/360$ or 9mm for transient loads.

Cusp 13 Beams - Span Tables for Rafters supporting sheet roof and ceiling (Eucalyptus nitens; Eucalyptus grandis)

Cross-section dimensions	Joist Spacing (mm)						
	300	350	400	450	500	550	600
W(mm) x D(mm)							
65 x 140	5200	5000	4800	4700	4600	4500	4400
65 x 190	6500	6300	6100	5900	5800	5600	5500
65 x 240	7800	7500	7300	7000	6900	6700	6600
65 x 294	9000	8700	8400	8200	8000	7800	7600
65 x 336	9900	9600	9300	9100	8800	8600	8400
65 x 360	10400	10100	9800	9500	9300	9100	8900
65 x 400	11100	10800	10600	10300	10100	9800	9600
85 x 294	9500	9200	9000	8800	8500	8300	8200
85 x 336	10300	10100	9900	9700	9400	9200	9000
85 x 360	10800	10600	10300	10100	9900	9700	9500
85 x 400	11600	11300	11100	10900	10700	10500	10300

These span tables have been prepared following design methods and loads prescribed in:

- AS 1720.1:2010 Timber Structures - Part 1: Design Methods.
- AS1720.3:2016 Timber Structures - Part 3: Design criteria for timber-framed residential buildings.
- Floor mass up to 40 kg/m². Live loads of 150 kg/m².

Notes

- W = member width, D = member depth.
- The values presented above were obtained based on the following assumptions:
 - Permanent loads: Floor mass up to 40 kg/m² + self-weight + 0.5 KPa of the live load
 - Live loads: Floor live load of 1.5 kPa
 - Structural models and load combinations as per AS 1720.3 - Section 4.1 Floor Joists $\Phi=0.95$
 - Load duration factor $k_1=0.57, 0.8$ and 0.94 for load categories 1, 2 and 3 respectively.
 - Modification factors for strength $k_4, k_7, k_9, k_{12}, k_{16}=1.0$
 - Modification factors for serviceability (deflections): $j_2=2.0$ for permanent loads and $j_2=1.0$ for transient loads.
 - Serviceability Limits: $L/300$ or 15mm for permanent loads, and $L/360$ or 9mm for transient loads.

Cusp 13 Beams - Span Tables for Ridge or Intermediate Beams (Eucalyptus nitens; Eucalyptus grandis)

Cross-section dimensions	Joist Spacing (mm)						
	W(mm) x D(mm)	300	350	400	450	500	550
65 x 140	5200	5000	4800	4700	4600	4500	4400
65 x 190	6500	6300	6100	5900	5800	5600	5500
65 x 240	7800	7500	7300	7000	6900	6700	6600
65 x 294	9000	8700	8400	8200	8000	7800	7600
65 x 336	9900	9600	9300	9100	8800	8600	8400
65 x 360	10400	10100	9800	9500	9300	9100	8900
65 x 400	11100	10800	10600	10300	10100	9800	9600
85 x 294	9500	9200	9000	8800	8500	8300	8200
85 x 336	10300	10100	9900	9700	9400	9200	9000
85 x 360	10800	10600	10300	10100	9900	9700	9500
85 x 400	11600	11300	11100	10900	10700	10500	10300

These span tables have been prepared following design methods and loads prescribed in:

- AS 1720.1:2010 Timber Structures - Part 1: Design Methods.
- AS1720.3:2016 Timber Structures - Part 3: Design criteria for timber-framed residential buildings.
- Floor mass up to 40 kg/m². Live loads of 150 kg/m².

Notes

- W = member width, D = member depth.
- The values presented above were obtained based on the following assumptions:
 - Permanent loads: Floor mass up to 40 kg/m² + self-weight + 0.5 KPa of the live load
 - Live loads: Floor live load of 1.5 kPa
 - Structural models and load combinations as per AS 1720.3 - Section 4.1 Floor Joists $\Phi=0.95$
 - Load duration factor $k_1=0.57, 0.8$ and 0.94 for load categories 1, 2 and 3 respectively.
 - Modification factors for strength $k_4, k_7, k_9, k_{12}, k_{16}=1.0$
 - Modification factors for serviceability (deflections): $j_2=2.0$ for permanent loads and $j_2=1.0$ for transient loads.
 - Serviceability Limits: $L/300$ or 15mm for permanent loads, and $L/360$ or 9mm for transient loads.

Cusp 13 - Span Tables for Common lintels (single or upper-storey walls)

Cross-section dimensions	Joist Spacing (mm)						
	300	350	400	450	500	550	600
W(mm) x D(mm)							
65 x 140	5200	5000	4800	4700	4600	4500	4400
65 x 190	6500	6300	6100	5900	5800	5600	5500
65 x 240	7800	7500	7300	7000	6900	6700	6600
65 x 294	9000	8700	8400	8200	8000	7800	7600
65 x 336	9900	9600	9300	9100	8800	8600	8400
65 x 360	10400	10100	9800	9500	9300	9100	8900
65 x 400	11100	10800	10600	10300	10100	9800	9600
85 x 294	9500	9200	9000	8800	8500	8300	8200
85 x 336	10300	10100	9900	9700	9400	9200	9000
85 x 360	10800	10600	10300	10100	9900	9700	9500
85 x 400	11600	11300	11100	10900	10700	10500	10300

These span tables have been prepared following design methods and loads prescribed in:

- AS 1720.1:2010 Timber Structures - Part 1: Design Methods.
- AS1720.3:2016 Timber Structures - Part 3: Design criteria for timber-framed residential buildings.
- Floor mass up to 40 kg/m². Live loads of 150 kg/m².

Notes

- W = member width, D = member depth.
- The values presented above were obtained based on the following assumptions:
 - Permanent loads: Floor mass up to 40 kg/m² + self-weight + 0.5 kPa of the live load
 - Live loads: Floor live load of 1.5 kPa
 - Structural models and load combinations as per AS 1720.3 - Section 4.1 Floor Joists $\Phi=0.95$
 - Load duration factor $k_1=0.57, 0.8$ and 0.94 for load categories 1, 2 and 3 respectively.
 - Modification factors for strength $k_4, k_7, k_9, k_{12}, k_{16}=1.0$
 - Modification factors for serviceability (deflections): $j_2=2.0$ for permanent loads and $j_2=1.0$ for transient loads.
 - Serviceability Limits: L/300 or 15mm for permanent loads, and L/360 or 9mm for transient loads.

If you still have questions about our products, please contact Cusp professionals for any information about the purchasing and use of Cusp products by phoning **1300 792 519** or on our website www.cusp.com.au



PRODUCT CERTIFIED

