



HOW TO:

Build your StudentBuddy



**SOLAR
BUDDY**

PRODUCT FEATURES

StudentBuddy is a sophisticated and powerful solar system, designed to be programmed and assembled, incorporating USB charging capabilities.

The following pages will provide detail of the design and its features.

Solar Panel

- ✓ All aluminium parts 100% recyclable
- ✓ 100% repairable design
- ✓ Lockable stand for floor or roof mounting
- ✓ Cable management feature
- ✓ Compact and lightweight design

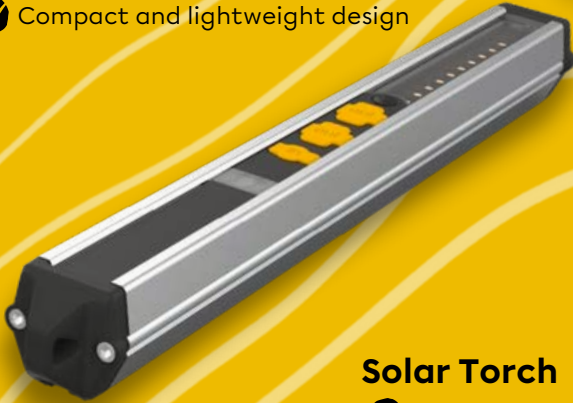

Solar Torch

- ✓ All aluminium parts 100% recyclable
- ✓ 100% repairable design
- ✓ Rugged and sustainably designed
- ✓ Rechargeable
- ✓ Power pack storage capabilities
- ✓ Enclosure rating to IP54
- ✓ Materials UV stable for up to 5 years in full sun

Connections

Input: DC input to charge light from the panel

Output: 5V output for 2 USB charging ports

Torch

Output: 150 lumens

Battery Life: up to 5 hours

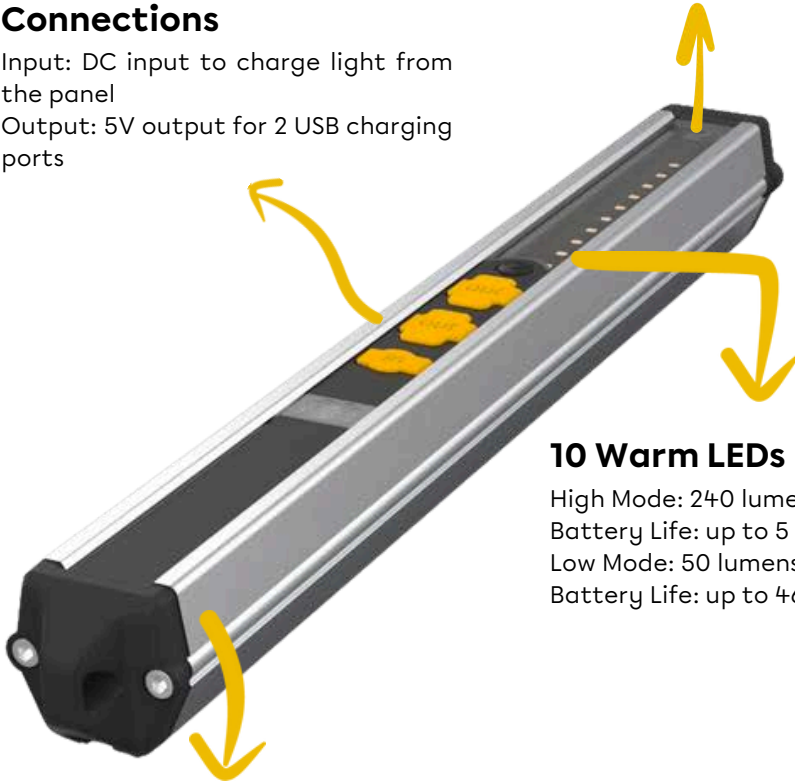

10 Warm LEDs

High Mode: 240 lumens

Battery Life: up to 5 hours

Low Mode: 50 lumens

Battery Life: up to 46 hours

Battery

3.7V Lithium Battery

Capacity: 3000mAh

SOLAR BUDDY

STUDENTBUDDY KIT

Recycled Paper Pulp Box

Fits both the StudentBuddy
light and solar panel kit



Solar Panel

Components on the top tray

Solar Light

Components on the bottom tray

Check your parts!

THE TORCH

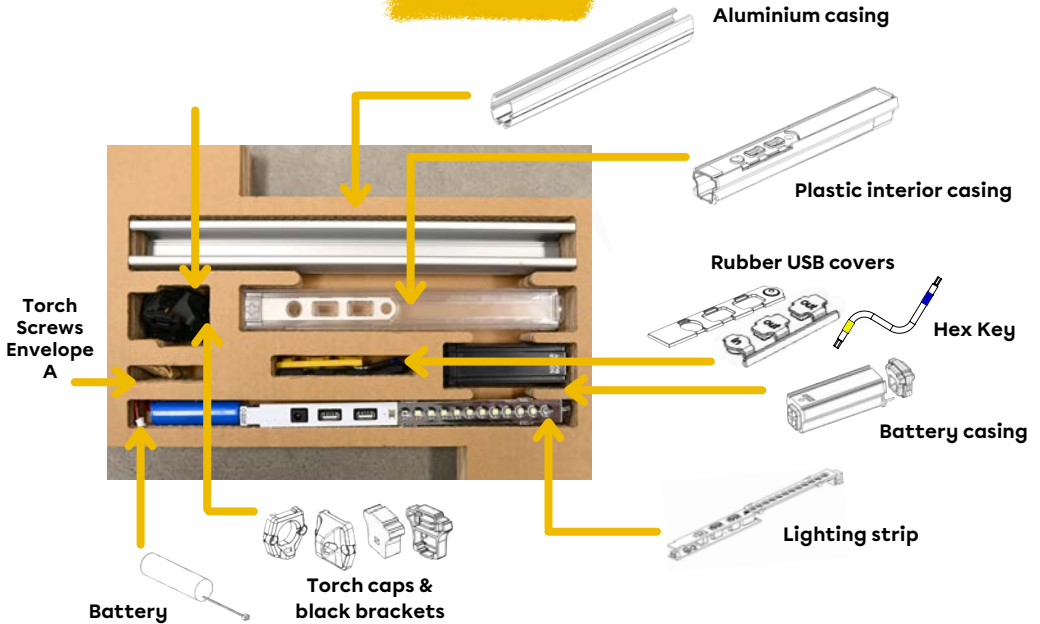

THE PANEL

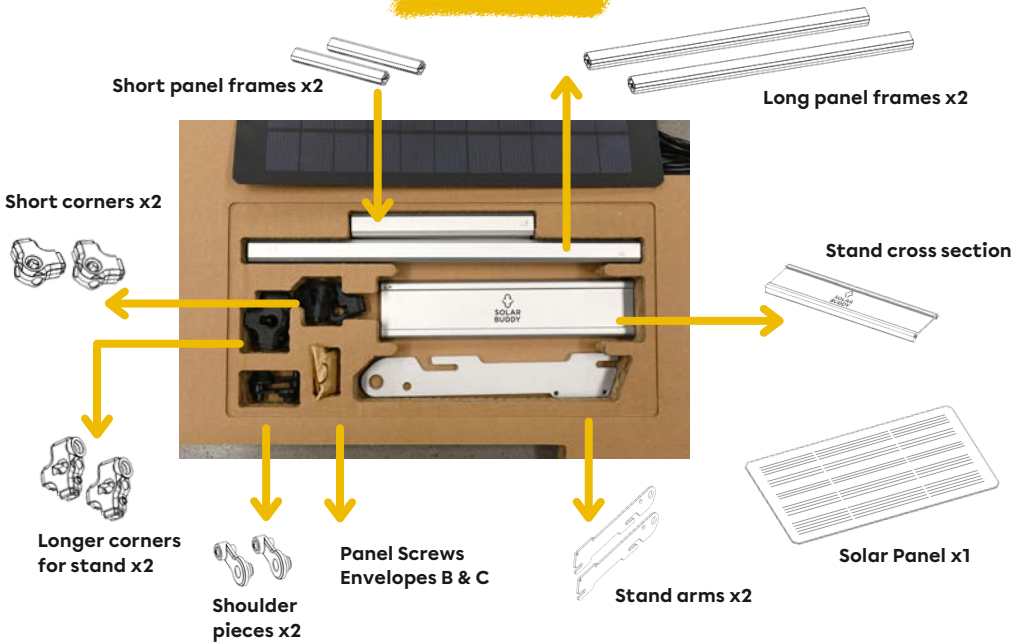

TOOLKIT

There is only one hex key tool for each StudentBuddy device. Don't forget to share with the team!

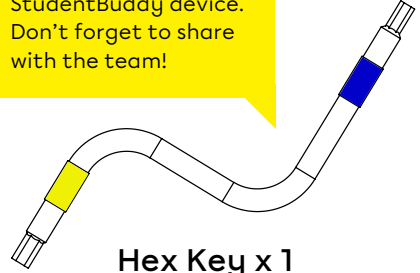

Check that you have all your components ready to build!

SCREWS



LIGHT
Envelope A



PANEL STAND
Envelope B



PANEL FRAME
Envelope C

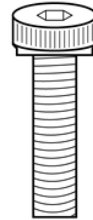

LONG SILVER SCREWS SECURES BOTH ENDS OF THE LIGHTS TO THE METAL CASING

A x4

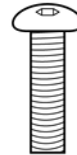

SHORT SILVER SCREWS CONNECTS THE ARMS OF THE STAND

B x4

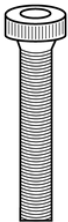

SHORT BLACK SCREWS X8

SHORT SCREWS ARE ONLY USED TO CONNECT ALL LENGTHS OF THE FRAME TO THE CORNERS

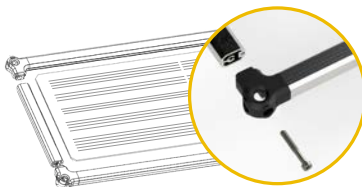

C2 x8



LONG BLACK SCREWS X2

LONG SCREWS ARE ONLY USED TO CONNECT THE SOLAR PANEL FRAME TO THE STAND

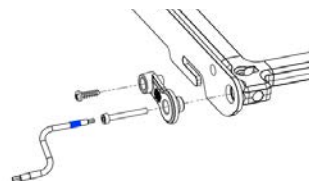

C1 x2



**SOLAR
BUDDY**



PART 1

Solar Torch Instructions

1

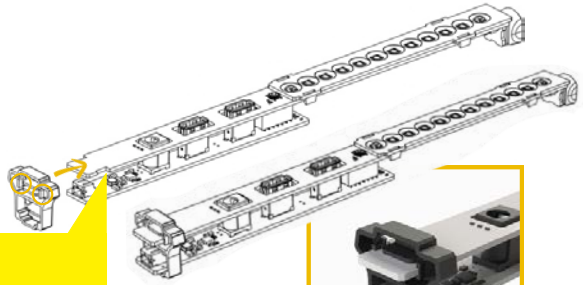

With the tabs facing outwards, slide the black bracket over the outer edge until it clicks over and sits in the ridge on the top of the lighting strip.

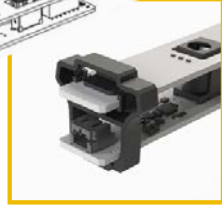

2

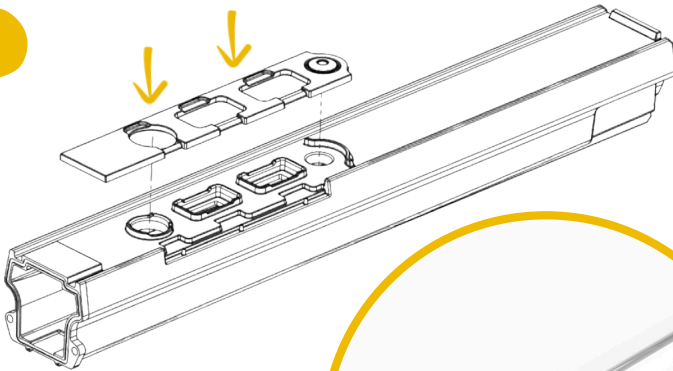

3

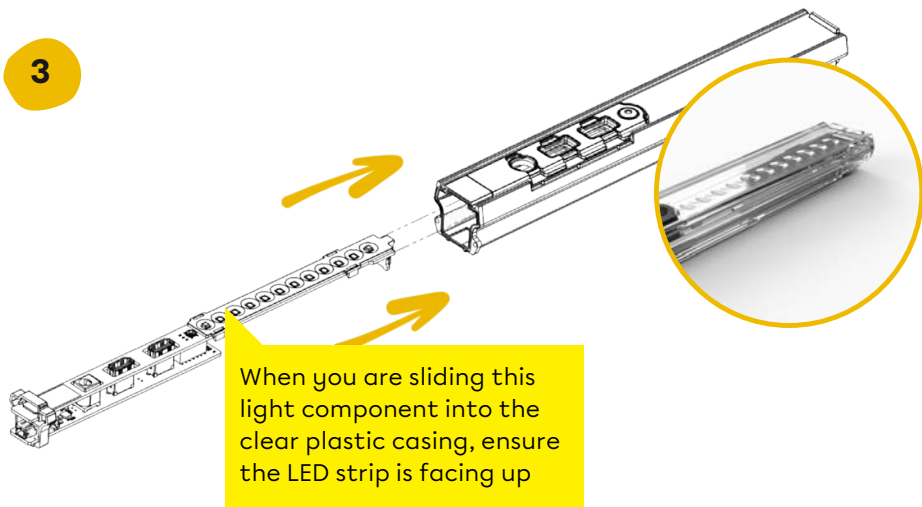

4

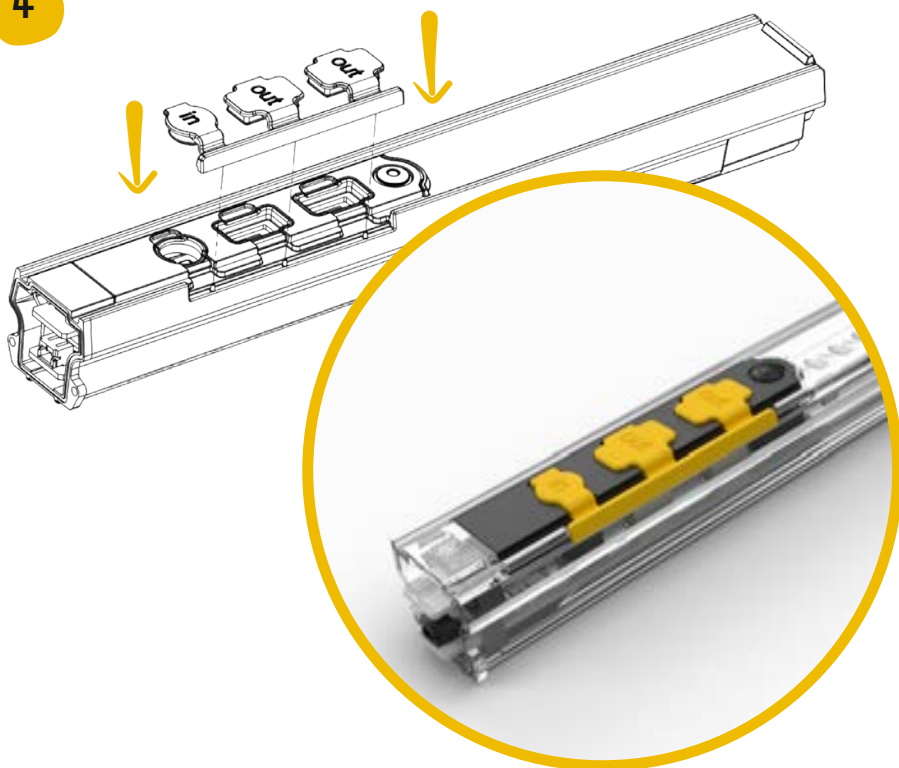

The battery container you receive is provided in the tray with 2 pieces. Once the battery install is complete these will be put back together to secure the battery.

5

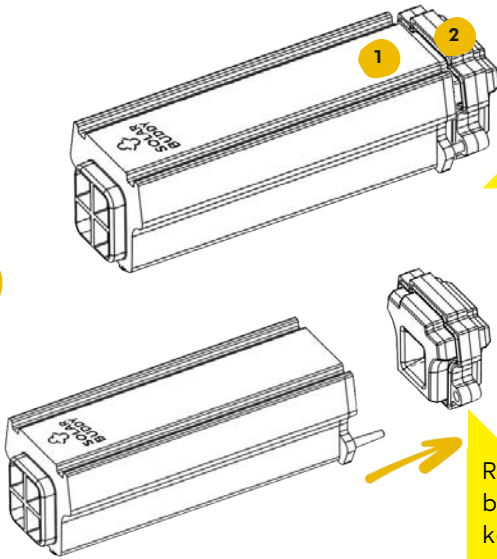

Remove the cap from the battery container but keep it close by. You will need it shortly.

6

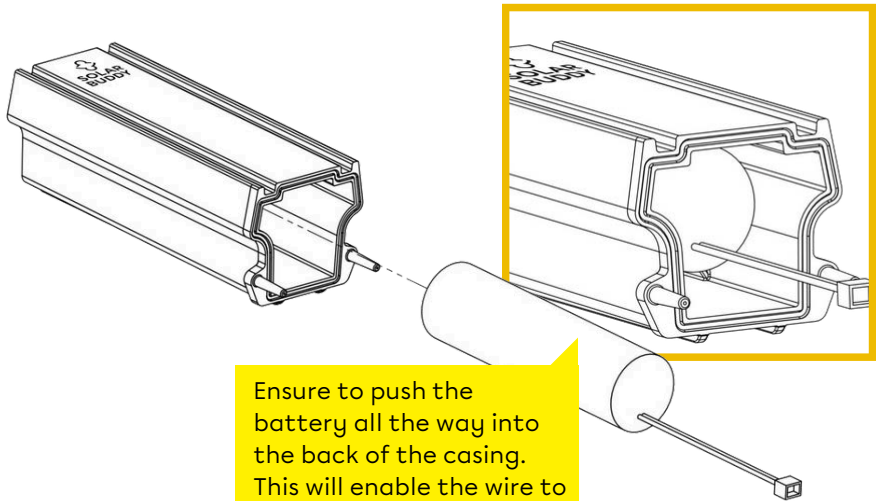

Ensure to push the battery all the way into the back of the casing. This will enable the wire to fold and fit inside.

7

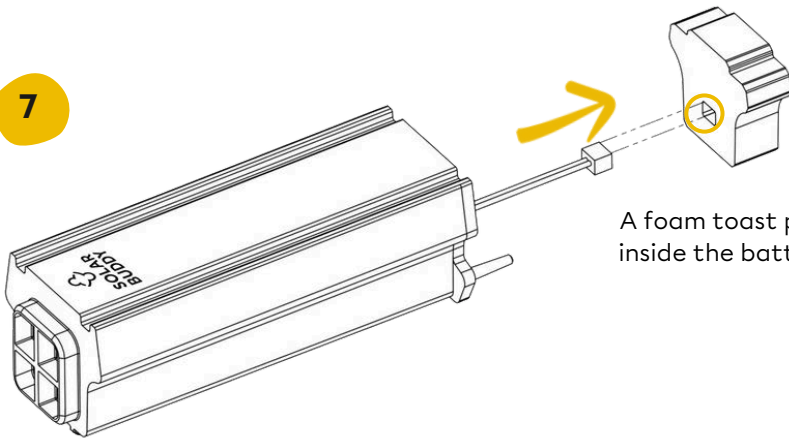

A foam toast piece sits inside the battery case

8

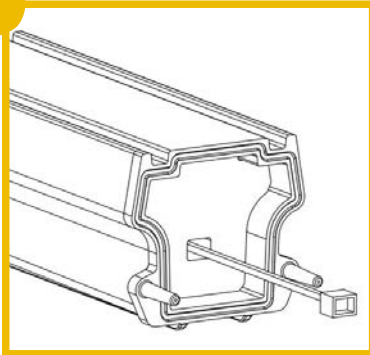

Remove the foam 'toast' element

This foam piece will act as a protective buffer.

There will be a small square cutout section in the foam piece to remove so that the wire can feed through

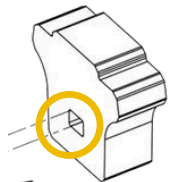

9

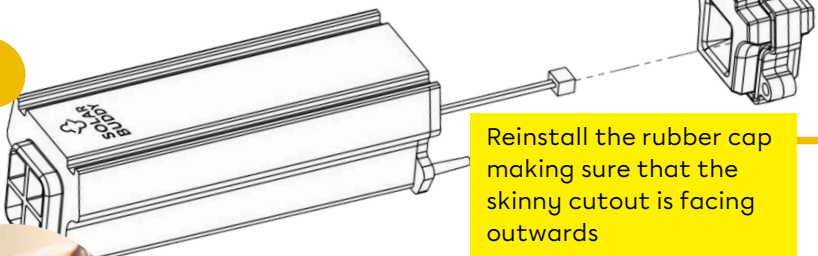

Reinstall the rubber cap making sure that the skinny cutout is facing outwards



Don't forget to fit the toast back in!
Fitting the foam 'toast' element before reinstalling the rubber cap is very important for protecting the battery

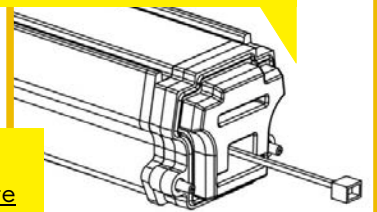

10

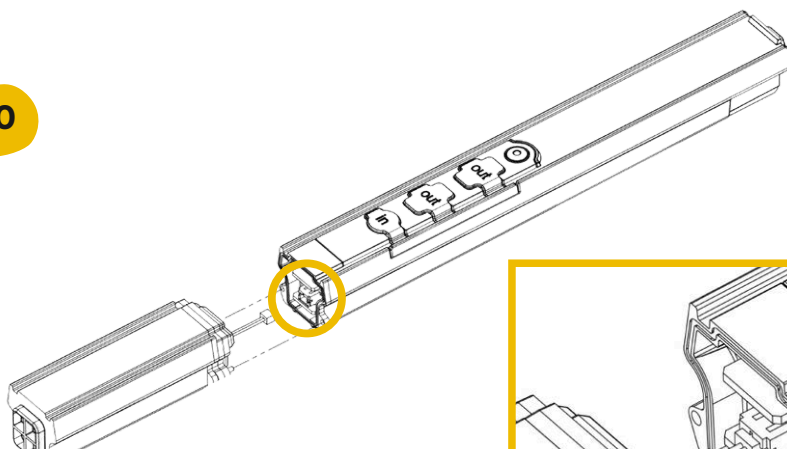

Installing the wire is a fiddly process. You may need to push some of the wire back into the container if there is too much on the outside, as it causes resistance and won't install to the input.

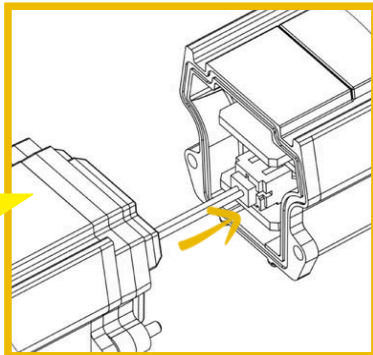

11

Once the wire is plugged in, lock the battery compartment into the light.

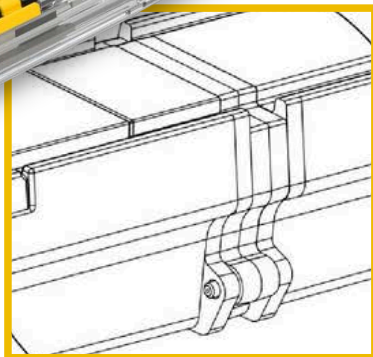

FOR THIS STEP YOU'LL NEED

Hex Key

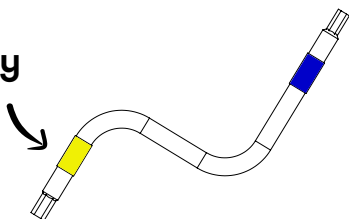

Envelope A

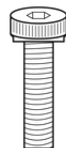

A x2

SILVER SCREWS

12

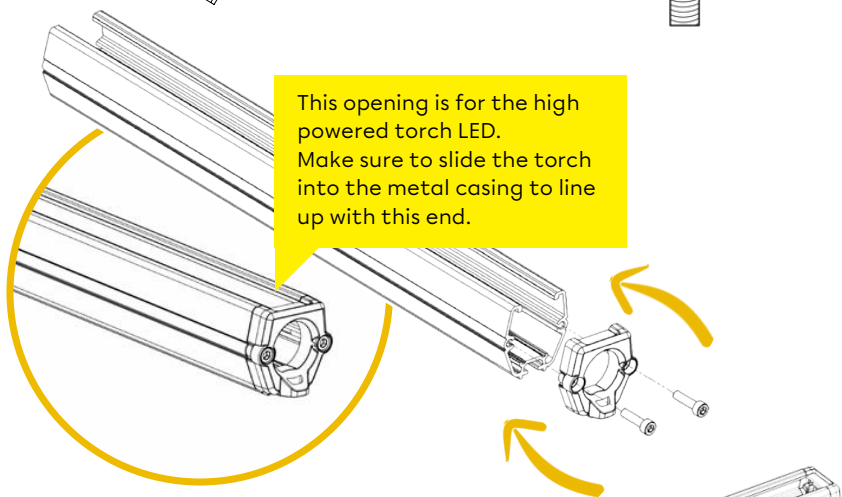

13



It can be difficult to slide the light into the metal casing if the rubber button and input covers aren't flat. Ensure they are tucked in completely so they don't block the channel.



FOR THIS STEP YOU'LL NEED

Hex Key

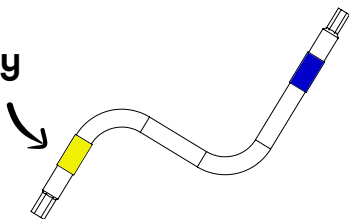

Envelope A

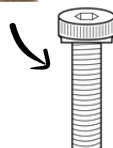

A x2
SILVER SCREWS

14

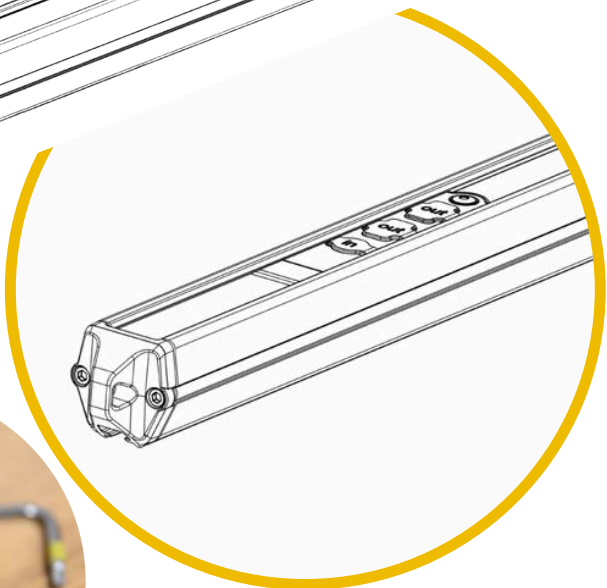
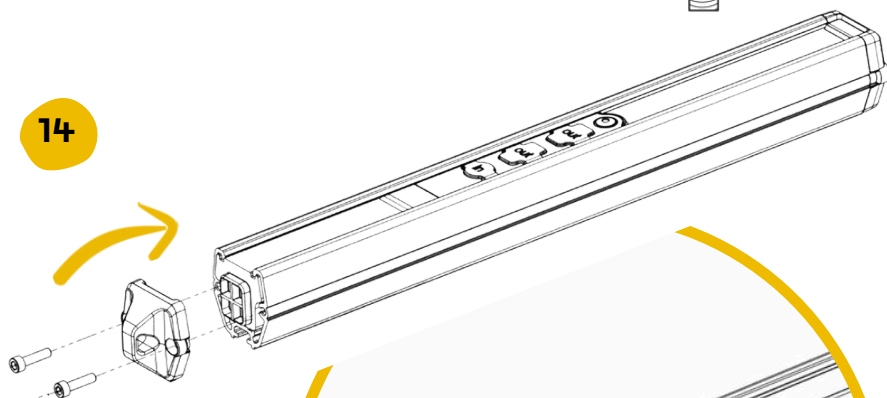



**SOLAR
BUDDY**

TEST YOUR LIGHT NOW!

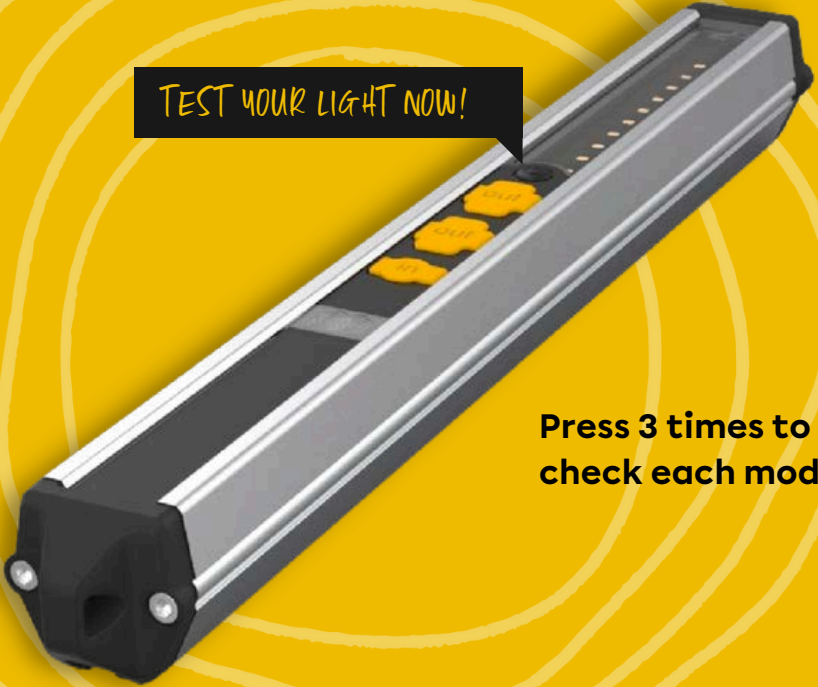

**Press 3 times to
check each mode**

FINAL LIGHT



**SOLAR
BUDDY**



PART 2

Solar Panel Instructions

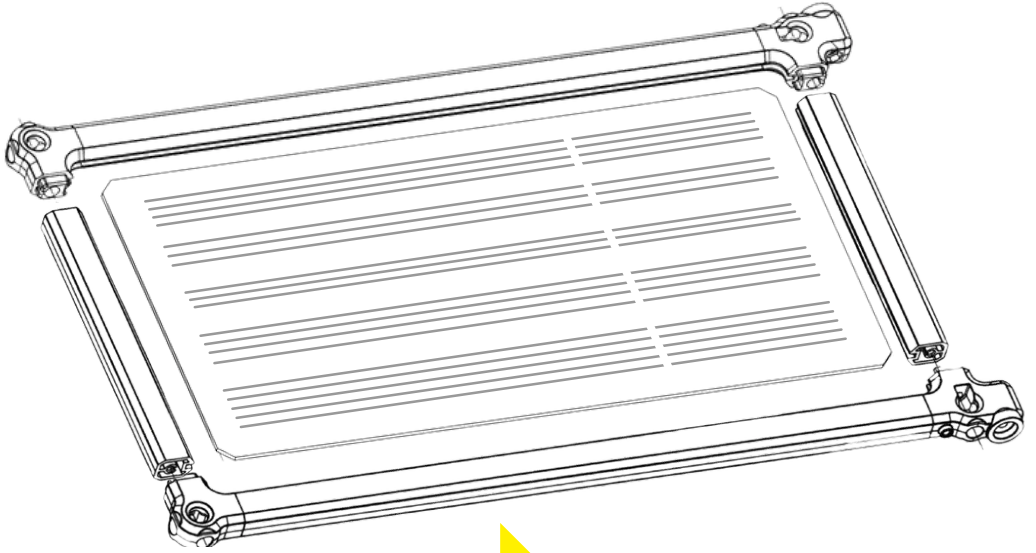

Use this as a guide to make sure the panel can slide into the grooves and the corners are facing the right way.

You may find it useful to lay the pieces of the panel out like this before starting to build the frame.

FOR THIS STEP YOU'LL NEED

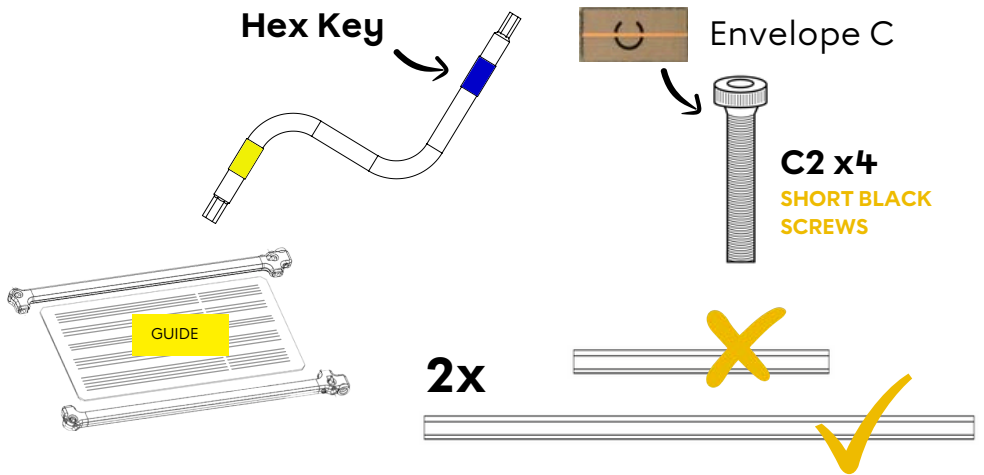

1

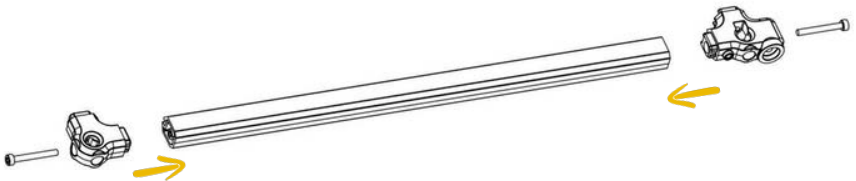

The inside grooves hold the solar panel in place on the frame and the corner pieces

2

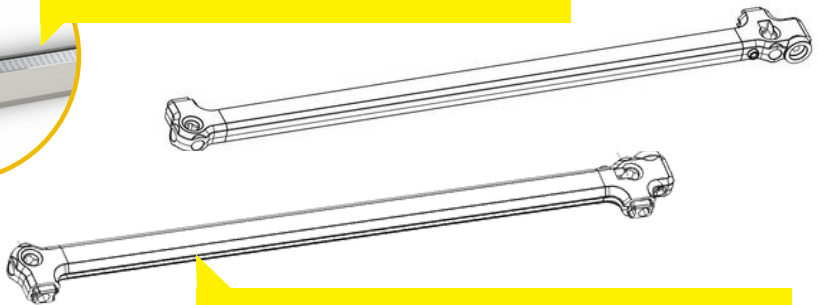

Repeat the above process to complete the parallel side of the panel frame. Refer back to the guide above to make sure the grooves on the frame pieces, as well as the corners are facing inwards to hold the panel.

FOR THIS STEP YOU'LL NEED

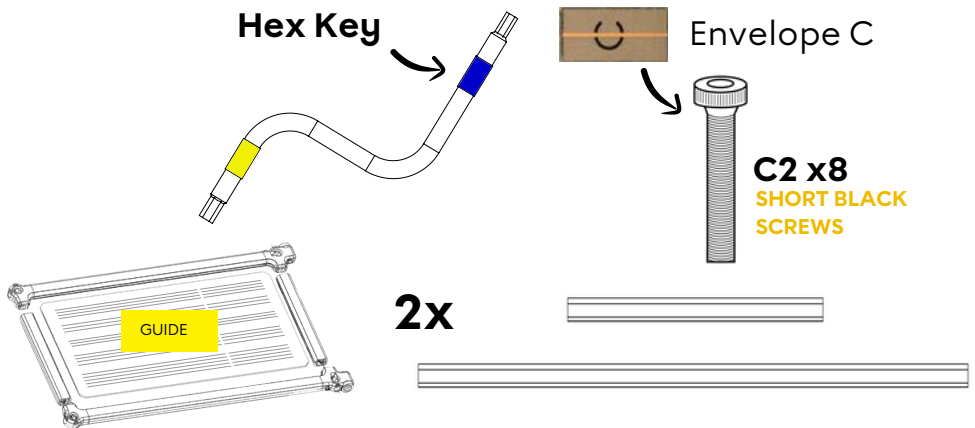

1

Assemble one half of the solar panel frame in the form of an L shape. Screw together using **short black screws**.

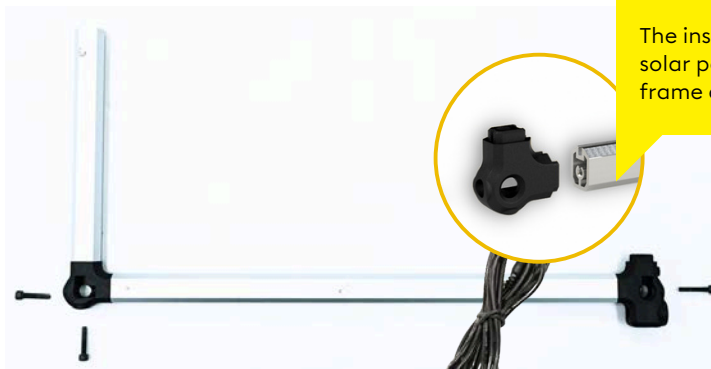

The inside grooves hold the solar panel in place on the frame and the corner pieces

SHORT BLACK SCREWS

2

Slide the solar panel into the inner grooves of this half of the frame.



3

Assemble the remaining half of the solar panel frame, also in L shape form. Screw together using the **short black screws**.

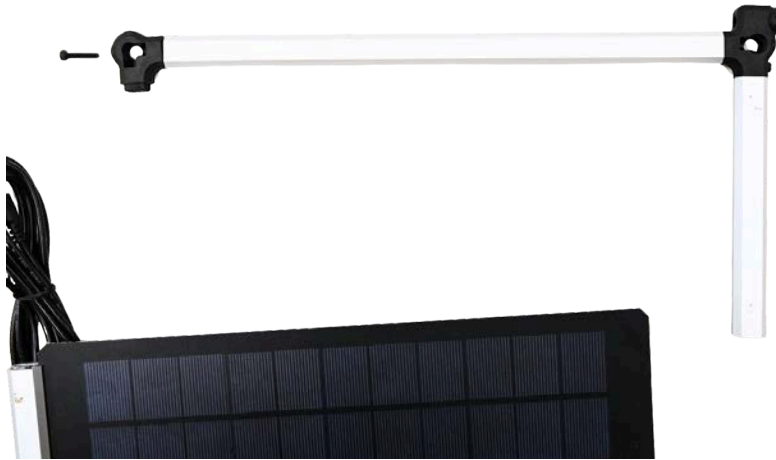

4

Slide this frame into the panel and align with the first half of the assembled frame. Ensure the solar panel is sitting in the grooves.

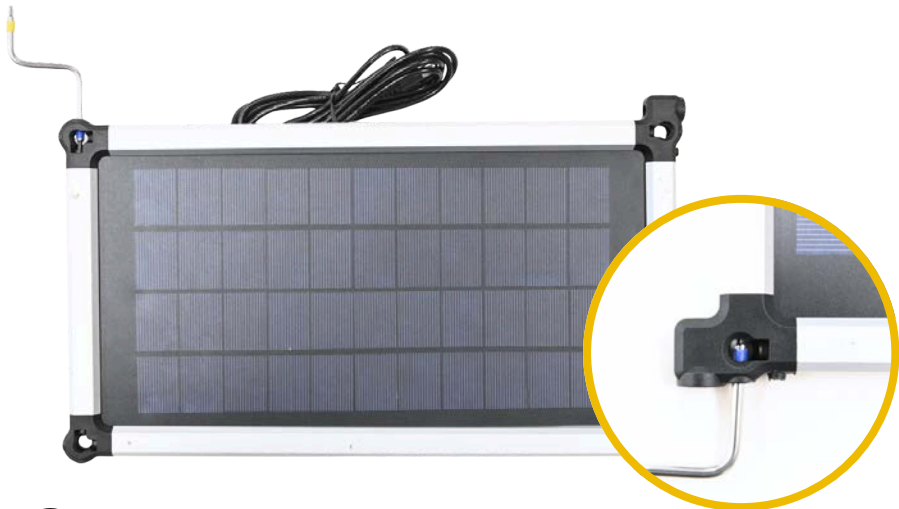

5

Once firmly in place, screw into place with remaining **short black screws**.

Ensure all screws are in place tightly. There should be no loose screws in any of the corners.

FOR THIS STEP YOU'LL NEED

Hex Key

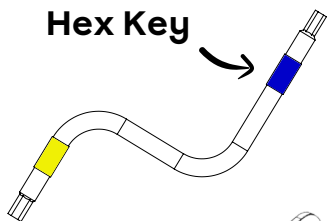

Envelope B

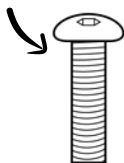

B x4

**SHORT BLACK
SCREWS**

6

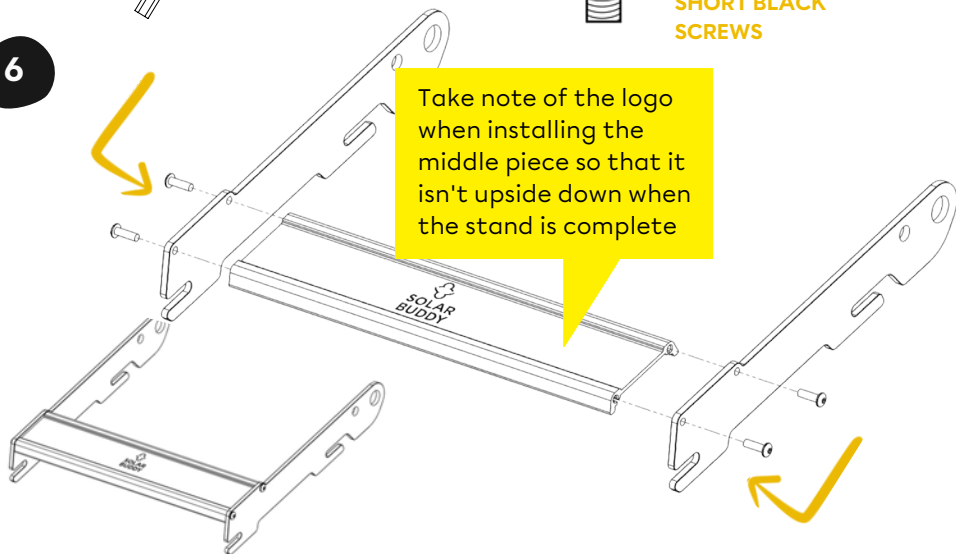

7

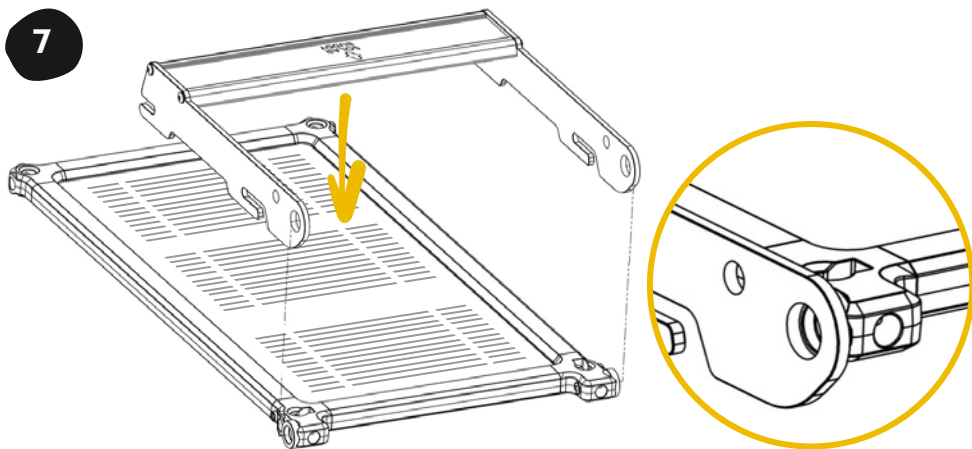

FOR THIS STEP YOU'LL NEED

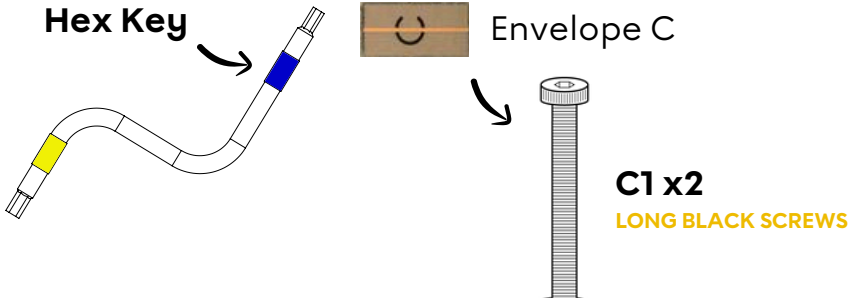

8

TIP: This step is made easier by collaborating! Work with a buddy - one to hold the stand and panel in place whilst the other installs the black shoulder piece. If you hold it up with the long piece on the table, it is much easier to keep it steady

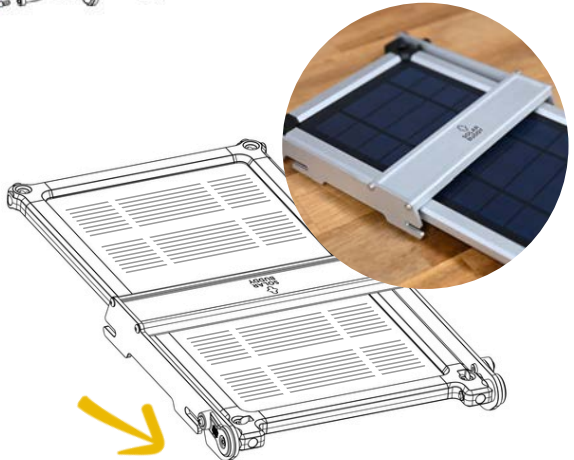
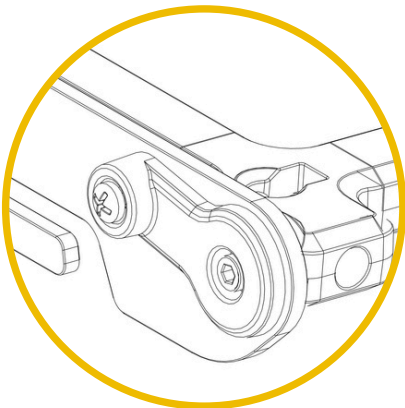
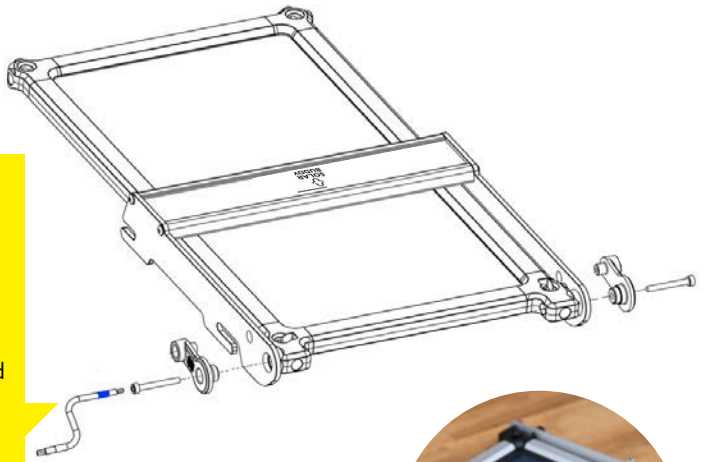

FINAL SOLAR PANEL



This panel's job is to charge the light to **illuminate futures**

CONGRATULATIONS!

You've completed the StudentBuddy Program!
Share your builds with us **#solarbuddy**



@solarbuddy_global



@solarbuddy.org



@solarbuddyorg



@solarbuddy



@SolarBuddy



LetterBuddy Program

Because words have power

You are already transforming lives with light, and now you can send a letter of encouragement to a child who will receive this gift.

Words have power and this is a wonderful way for you to convey a message that otherwise may never be heard.

Your letter will be treasured and reread many times, as this is often the most formal communication the children have ever seen.

**Ready to connect direct
with your buddy?**

Letter writing guide:

- Use pen instead of pencil to avoid smudging
- Write clearly and use simple language so that English learners are encouraged to understand your message
- Include some unique details about yourself like what sport or hobbies you enjoy, or how many family members or pets you have. Leave out personal details such as your address, surname, phone number or social media details
- Write at least half a page as students who receive one sentence may feel left out
- Be creative! You are welcome to include colourful designs and drawings but please don't include inappropriate images
- Please refrain from religious references as we can't know whether the person receiving your letter is a part of a particular faith
- Be positive! Your perception of their difficulties might be different to theirs
- Have fun! The light you have built will have a lasting positive impact

Letter example:

My name is Grace and I am so happy to be able to gift you this light! I am excited to see what you achieve by using this light!

I live in a city called Brisbane in Australia. I like playing football after getting back from school. I have a little pet dog who is four years old. I play games with her all the time. I built this light for you with my classmates because I want you to be able to study at night, just like I do.

When I grow up, I want to be a doctor. I hope you achieve everything you want!

Lots of Love, Grace.

What kind of message would you like to receive?

Think about who is receiving your letter and how special this piece of paper is to these children!



STUDENTBUDDY PACKING GUIDE

1 Take the component inserts out of the middle of the box

2 Arranging inserts

Turn the outside inserts around so that they are positioned on the sides of the box. This creates the zones in which to place the finished panel and torch.

3 Place the completed kits into the box

Place the panel into the wider grooved zone of the box - then place the torch into the narrow zone of the box.

NOTE: 1x StudentBuddy device will fit back into a SolarBuddy kit box. Please ensure that the components are secured in place before closing.

4 Insert your written letter & hex key

Once you have written your letter, simply insert it between the frame and the panel. Add in the hex key aside the panel.

5 Close kit boxes

Ensure that all boxes are closed flat without any protruding parts of the box, and that they are facing with the SolarBuddy logo at the top before packing into the shipping box.

6 Pack kit boxes into shipping box

8x kit boxes will fit back into the shipping box
Left over component inserts can be recycled



CONGRATULATIONS

You've now completed your StudentBuddy build!
To request collection of your shipping box(s), please visit:
www.solarbuddy.org/collection